



CITY OF INDUSTRY, CA
BROOKSHIRE, TX
BOLINGBROOK, IL
JERSEY CITY, NJ
POOLER, GA
CONTACT US
SALES: 447-902-3857
TECHNICAL: 716-299-8852
EMAIL: INFO@AUTOKATO.COM



Read the entire contents of this manual before using this product. Failure to follow the instructions and safety precautions in this manual can result in serious injury or death. Make sure all other operators also read this manual. By proceeding with setup and operation, you agree that you fully understand the contents of this manual and assume full responsibility for product use.

Description

The hydraulic parking lift is the device that developed through continuous research. The device enjoys great popularity with the features of simple structure, easy assembling and space-saving.

The device is mainly consists of posts of two sides, carriage of two sides, and wave plate platform. The left and right post can be used in common. The left and right carriage can from double- linked or multi-linked device with the column at random.



Diagram (1) Single set

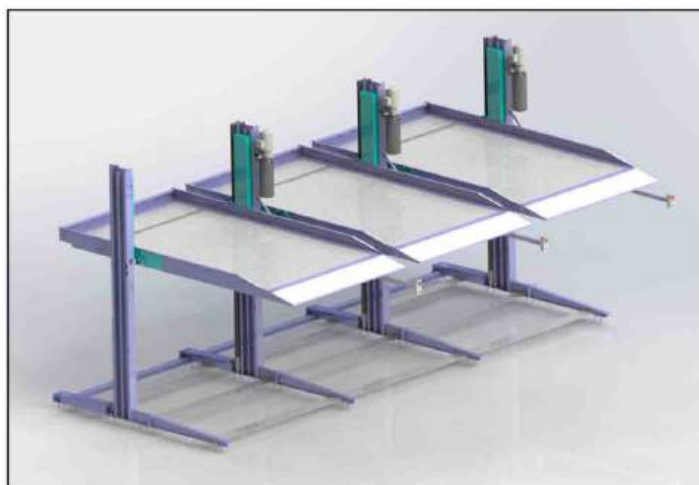

Diagram (2) Multiple linked unit

Outline size

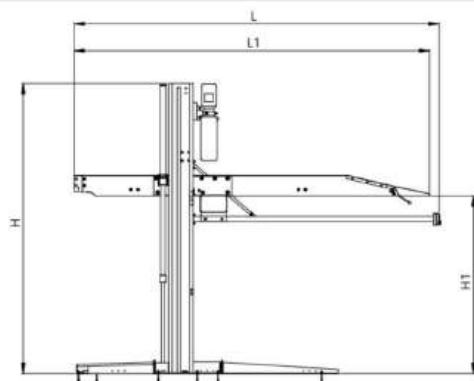

Diagram (3) Left elevation

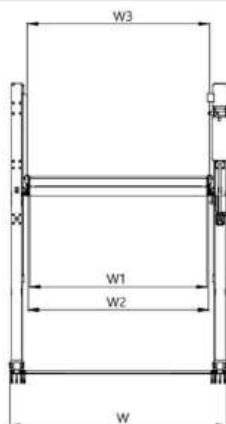

Diagram (4) Front elevation

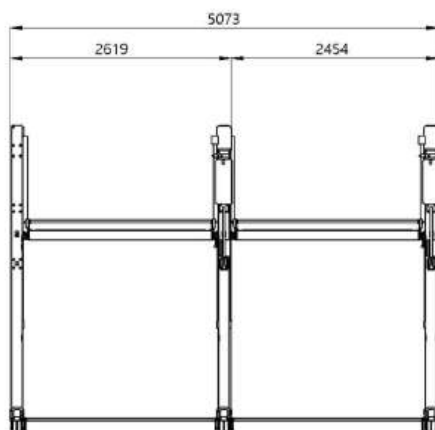

Diagram (5) Multiple linked unit



The size of the device that made according to the requirement of the customer should be based on the real size of the device.

Size code	Size name	Value/mm
L	Device length	4405
L1	Platform length	4288
W	Device width	2619
H	Device height	3500
H(Optional)	Device height	3055
H1	Platform height	$5 \leq H1 \leq 2140$
W1	Car capacity width	2100
W2	Platform width	2174
W3	Width between carriages	2199

Specification

CAPACITY	3,000 kg
MIN. PRESSURE	200 kg/cm ²
MAX. HEIGHT	2100mm
MIN. HEIGHT	100mm
STROKE)(' ' mm
LIFTING TIME	60~80 sec.
LOWERING TIME	40~60 sec.
POWER & MOTOR	220V / 110V 50Hz / 60Hz
Gross weight	1,160 kg

Device layout

Before you install the lift, you should check the following items:

- The working area should be well designed and has enough space.
- Avoid barrier like electric wire to exist in installing area.
- Check carefully if there is crack on the concrete ground that install the lift and check if the strength of the concrete can reach the requirements. The compressive strength should be no less 200kg/cm². And the thickness of concrete basement should be no less than 300mm, the strength should be no less than 250 class, the just finished concrete basement must be solidified and kept over 28 days. Otherwise, the lift will crush the ground, which will cause the damage of equipment and injury & death of people.
- The installation basement must assure certain levelness; the tolerance is not allowed over 5mm, the tolerance within this limit can be adjusted by using washers. If the ground is uneven seriously, you should fix it up.
- Not allow to install equipment on the pitch ground or other non-concrete ground.
- Prohibit installing equipment on the ground with craze or junk concrete ground.
- Prohibit installing equipment on second floor or higher floor without the approval of architect.
- If there are no protective measures, please do not install the equipment outdoor to avoid something wrong with the motor in rainy days.
- Confirm the general installation position of the equipment, and then put columns and platform on their respective places. Please the platform between the two columns.
- Confirm the location of the electric cabinet and keep enough space for operation.
- Draw up the position of the baseboard of the column with chalk after the confirmation to assure the tolerance within 3mm to avoid effecting the installation of the lift.
- Check carefully to assure the layout is correct.

Tools to install the device

Hammer, Level, Open spanner, Socket head wrench, Adjustable spanner, Crow bar Chalk or color pen, Flat screw driver, Tape measure (5m), Nipper pliers

Installation steps

- Install the inversion cylinder and oil hose. Place the column on the ground, remove the carriage to the top of the column, then work the oil hose 1 into from up to the bottom, and out from the square hole on the bottom, and then place the bottom end of the cylinder on the circle hole of the tray, fix the top end of the piston rod on the cylinder fixed support. And then connect the oil hose 2 with the top end of the piston rod. Then move the carriage to the bottom of the column to make the tray connect with the retainer ring of the cylinder. Likewise, place another side on the ground evenly, and install the second cylinder.

Installation

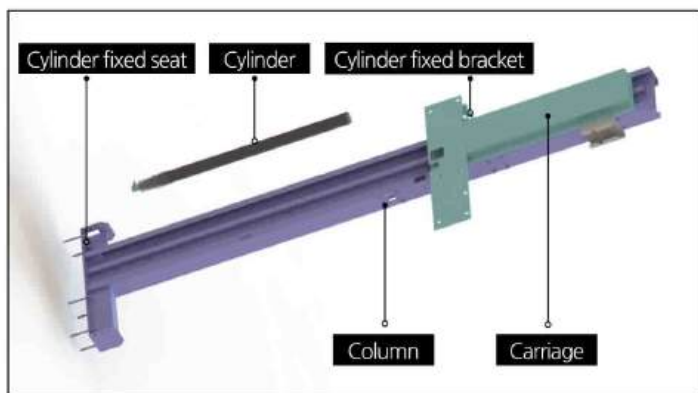

Diagram (5)

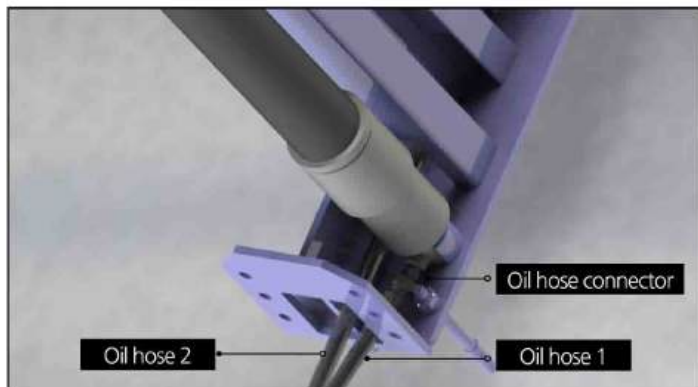

Diagram (6) Connecting oil hose

- Firstly connect the left side beam, right side beam and platform rear adapter and rear stopper together, and then install the rear cover, install 16 wave plate in turn, at last install front plate to driven car on, after installation, conduct diagonal adjustment to make the distance between the two diagonal line less than 20mm.

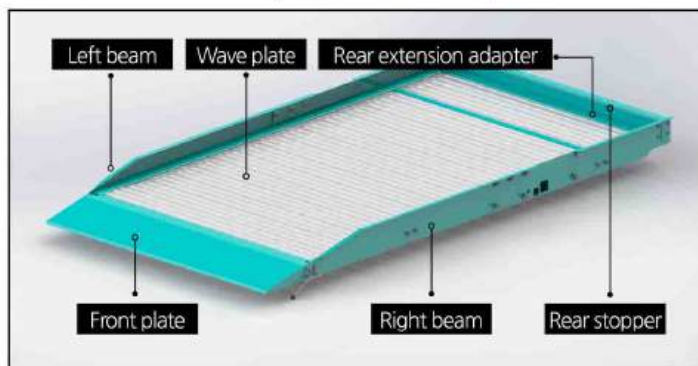

Diagram (7) Platform

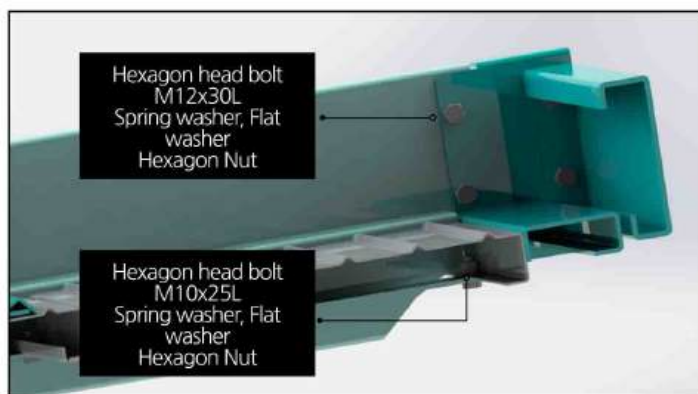

Diagram (8) Rear cover & wave plate installation (section)

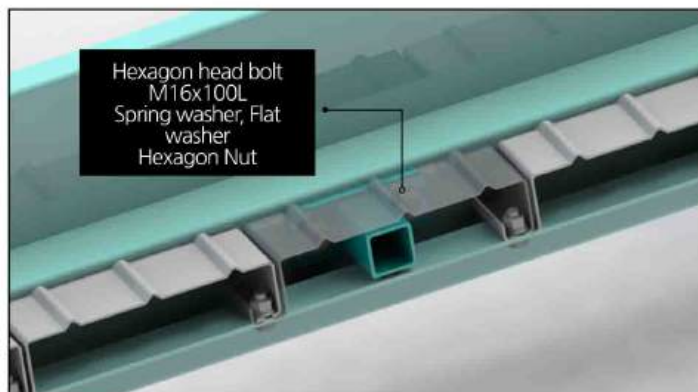

Diagram (11) Platform pull rod installation (section)

- Erect up the column, connect the column base support and the column with the bolt on the front leg of column and the oil hose guide slot. Connect the carriage connection plate and the platform side beam with the bolt.

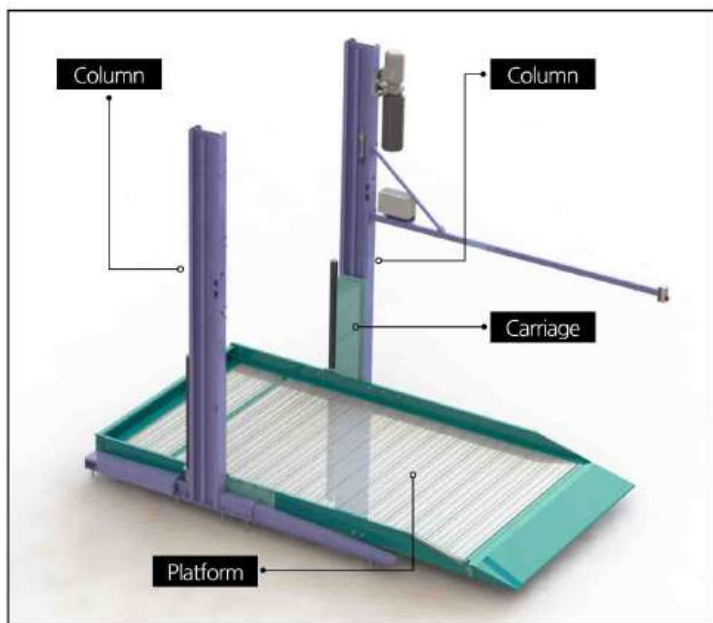

Diagram (12)

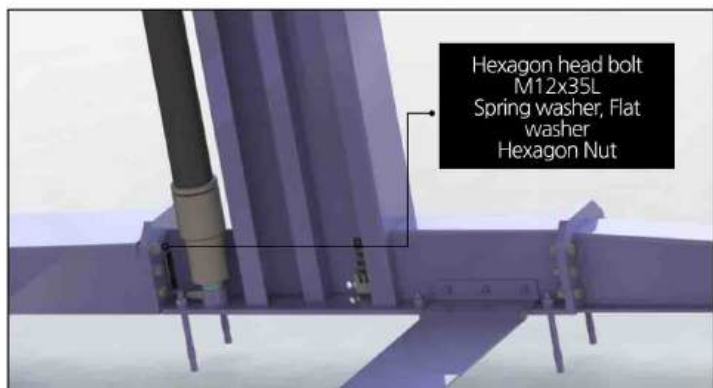

Diagram (13)

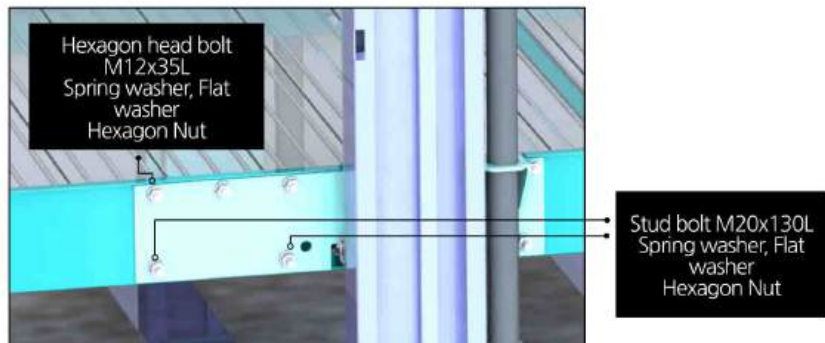

Diagram (14)

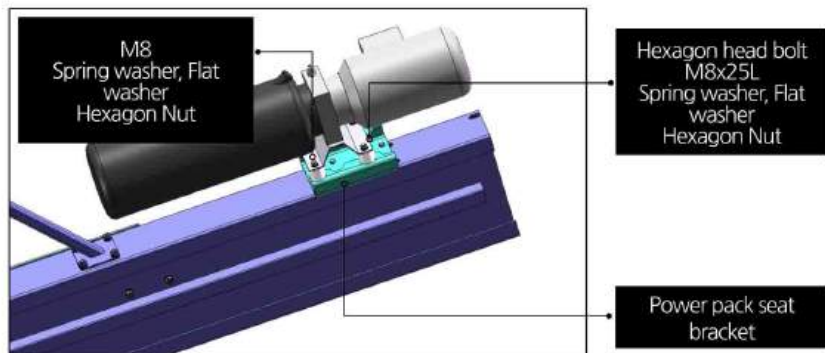

Diagram (15)

- Hang up the power pack. Fix the motor support plate on the power pack first, and then suspend it on the top of the column.
- Connect the oil hose. Connect the oil hose 1 and the oil hose 2 with block. The other end of the oil hose 2 connect the power pack.

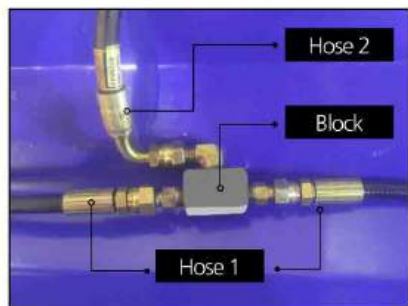

Diagram (16) the connection of oil hose

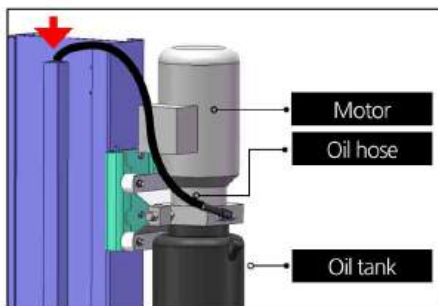

Diagram (17) the connection between the oil hose and the power pack

- Fix one end of the chain underneath the column, pull it out from the top of the chain pulley, pass through the opening of the platform, and pull it out from other end of the platform opening.

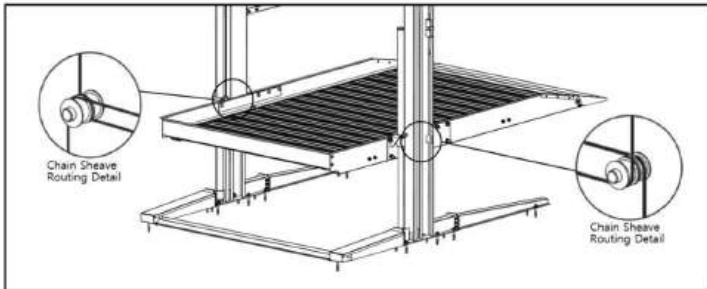

Diagram (18) chain installation sketch map

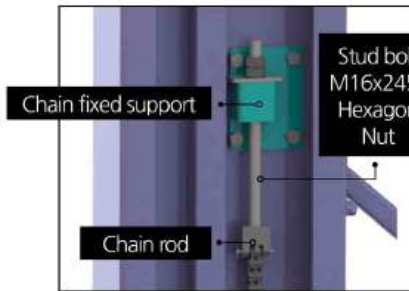

Diagram (20)

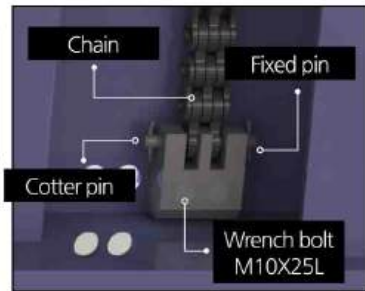

Diagram (21)

- Pull the chain out from the other carriage chain pulley and fix it on the chain fixed support on the top of the column.
- Connect the locking device. The live knot bearing and the lock release pull rod connect the manual lock release device, the nut on the pull rod adjust the tightness of the pull rod.

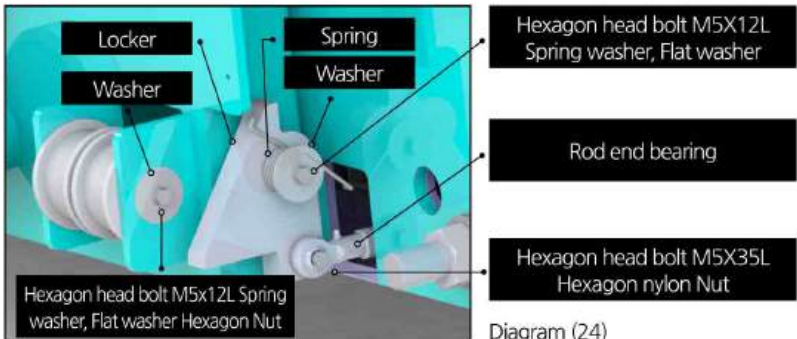

Diagram (24)

- Add appropriate hydraulic oil into the power pack, connect the power, and the start the power pack, control the lift of the platform with dot move lift control button, stop lifting when the platform rises to the height about 1m (one meter), fixed all the bolts of carriage and platform.

● Control arm installation and button box.

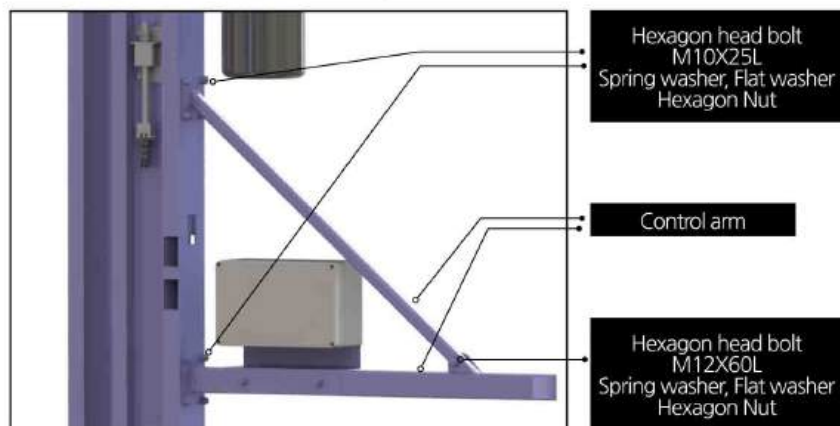

Diagram (30)

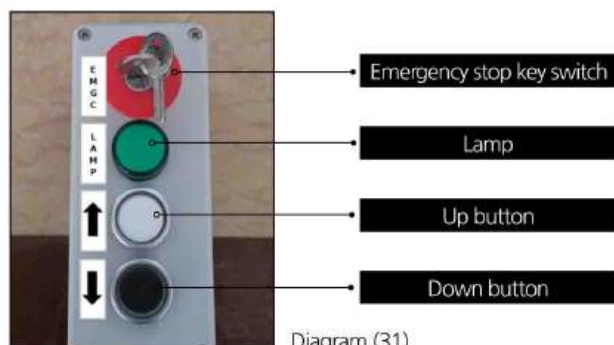

Diagram (31)

● Take base plate of post as a template to drill hole with electric hammer on the concrete ground. These holes should be about 120mm deep (d). Prohibit expanding the hole or shaking the hammer. After drilling hole, clear the inside of the hole and check the alignment of the base plate and chalk line.

● Hammer the stone bolt into the hole, until the washer touches the basement plate, if you want to underlay the U-type thin slice for the basement plate, set apart enough screw length.

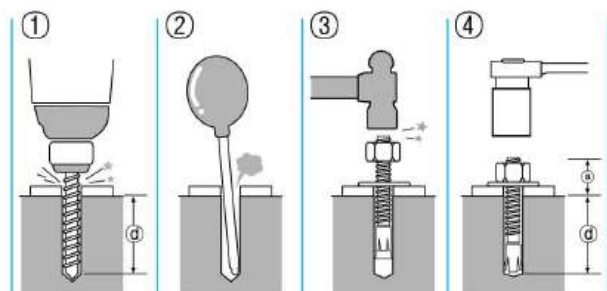

Diagram (32)

- If the column is uneven with the ground, you need to insert U-type thine slice to adjust. After fixing the stone bolt, the column will be vertical to the ground.

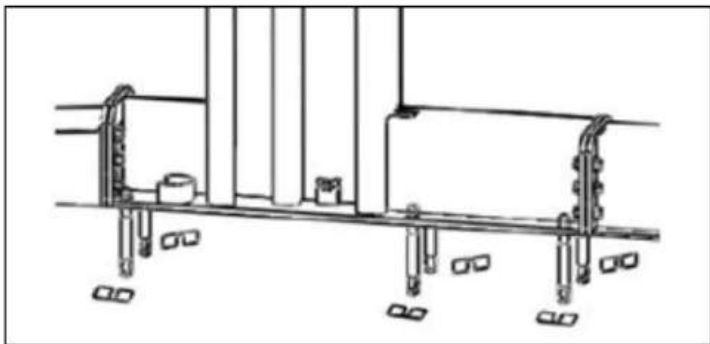

Diagram (33)

- Release the emergency stop key switch by rotating the key when you operate the lift.
- Press the emergency stop key switch when the emergency situation is occurred.
- Press the up button on the control box in the emergency stop key switch is released, the lift rising, the cylinder begin to work.
- When the lift rise to the highest position, stop pressing the up button, to avoid the damage of the cylinder.
- If you want to lower down, you should let it some rise distance, (about 10~20mm), and then unlock manually. Then press down button, lower the lifting height to half. Then manual lock releases, (attention: you can loose from the lock release when lock release block lowered to position under the lock release hole)
- At this time, loosen the exhaust bolt on the top of the cylinder, don't loosen it completely, screw it down after exhausting the air.
- Continue to press the down button, lower down the lift with safety. And then repeat to lower it down for several times, discharge the air in the cylinder.
Attention: during the whole lifting process, observe all the operation parts, check the correctness of the installation and the debugging. Only when you confirm that there is no any mistakes, you can start to operate the lift.
- After the installation and the debugging, lubricate each sliding parts with the lubricant.

Control System introduction

● Control theory

The lift of the platform can be controlled by dot move. The operator can control the lift of the platform with the up or down button, and then conduct the Vernier regulation of the lifting height according to the actual parking requirement.

When pick up the car, you should press the up button to let the car rise for some distance (about 10~20mm), and then pull the lock release handle to release the locking, and then press the down button to lower it down.

The top of the buttons in the control box of the control arm in front of the device, there is an emergency key stop switch. You should press the emergency stop key switch in an emergency situation, to power down the device, but after excluding the fault, rotate the button by the key to reset it, or the device still can't run.

● Control matters need attention

When assembling, confirm the fastness of the wiring: check if there is any visible wire end to avoid short circuit.

If short circuit occurs, the fuse protector will take effects. After that, the fuse should be changed.

The failure of the control system should be maintained by professional technicians. It is forbidden for the staff without electric service related knowledge to repair the device, to avoid of the body damage caused by electric shock or device damage cause by wrong wiring.

Prohibit exposing electric elements in damp environment to avoid short circuit.

● Parts of control problem

Symptoms	Possible reason	Check point and action
There is no reaction when pressing the button	The fuse of control circuit is burned.	Check and change the burned fuse.
	The power cord is open circuit.	Check the wire circuit to confirm the wire connection is right.
	The emergency stop key switch is pressed down.	Rotate the emergency stop key switch to reset it by the key.
The platform can't rise when pressing the up button, but can be lowered down when pressing the down button.	The platform has been in the highest position	Normal symptom.

Danger/Warning/Caution



- If the equipment will be not in service for a long time, the main power supply should be closed to avoid accident and to save energy.
- If the equipment has not been in service for a long time, please lubricate it and check if there is any damage and rust corrosion.



Make sure you follow the instructions, otherwise critical injury or death can occur.



Make sure you follow the instructions, otherwise critical injury or damage can occur.



Make sure you follow the instructions; otherwise, injury or damage can occur



The terms are described to enhance the understanding of the equipment.



Information to use the equipment efficiently.



Precautions or check points for the use of the equipment.



Please refer to the page



Do not come under the vehicle during operation.
- This can cause injury or death.



Evacuate to a safe place instantly in the event that the vehicle tips.
- This can cause injury or death.



Do not overload the rated capacity.
- This can cause injury or death.



Do not modify and remove the stopper.
- This can cause injury or death.



Warning before using the equipment

Only trained personnel may operate the equipment. Inexperience can cause accidents.



Position the vehicle to make sure that it is balanced front and rear, right and left (otherwise the vehicle may fall off).



Do not operate damaged equipment (a critical accident could occur - contact your Heshbon supplier)



After that a vehicle is placed on the lift make sure that the hand brake is applied. Passenger transport is forbidden.





Warning while operating

Allow no unauthorized persons in the work area.

Before lowering the lift, check that there are no obstructions under the vehicle or the lift arms.

When the vehicle is lifted, do not rock it as this may dislodge it.

Do not lift a vehicle using one pair of arms only.



Warning while operating

To avoid injury, keep your feet clear of the arms and carriages.

Before going under the lift, make sure that the safety pawls are engaged.

To avoid being electrocuted, disconnect the main power before opening the control panel.

Do not modify the control panel or the safety functions as this may impair their function.

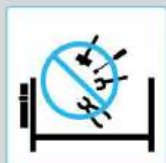

Warning when operating

Do not rock the vehicle when lifted. Do not use a high pressure cleaner as the vehicle lower part.

Read and fully understand the manual before using the lift

Warning before using the equipment

Check the safety devices to see that they are clean and operable.

If the lift is idle for a long time, disconnect the main power supply. In the event of thunder storm, disconnect the main power supply.



Operation

Parking

- Drive the car on the appropriate position of the platform. Avoid collision with the control cabinet and rear of the platform.
- Start the manual brake after the car on the position
- Open the car door carefully to avoid any collision with the car door.
- The driver leaves the drive cabin.
- Press the up button, lift the car to the appropriate position, and lock the lift. Take notice that the safety locking device should always be valid.
- You can park other vehicles under the platform, but before parking, check and confirm that all the vehicle height of the parked vehicle should be no more than platform height, to avoid the vehicle being scratched.

Take the car

- Be sure there is no person or obstacle under the car, if there is car parked under the platform, drive the car away from the device, to ensure not affect platform come down and pick up the car.
- Firstly, press the up button to lift the cylinder, to release the locking block. And then press the down button, to lower the platform to the ground.
- The driver enter into the operator cabin.
- Drive the car off the platform.

Maintenance and service

Maintenance

Conduct the maintenance every month regularly to ensure the use safety of the device and prolong the use life.

- Check if the carriage can work normally.
- Check if the chain, chain connector, chain pin shaft, cotter pin can work normally.
- Check if the expansion bolt is loose. You should tighten the expansion bolt if it is loose.
- Check whether the locking device can work normally, if the work of it is abnormal, find out the reason and exclude the fault.
- Check if there is any distortion of the column, Check is the column is vertical to the ground. You should stop operation the device if there is any serious distortion of the column caused by overload and abnormal use.
- Add the grease on the slide block that in the column.

Troubleshooting

Symptoms	Possible reason	Check point and action
The motor works, no hydraulic leakage, the sound is abnormal, but the platform can't rise.	There is air in the hydraulic oil.	Lift with idle load to the highest position, and keep for sends and then lower down, when lowered to the half-height, screw to open the oil hose connector, discharge the air and then screw down.
	The hydraulic oil solidify or viscosity of the hydraulic oil is too big as surrounding temperature is too low.	Discharge the hydraulic oil, refilling qualified hydraulic oil.
	The load is overweight	Check and confirm that lift weight is less than rated load.
Hydraulic oil leakage of oil hose connector	The connector is loose.	Screw down the tube connector
	The connector is damaged	Change the connector
Hydraulic leakage of the cylinder	The hydraulic seal kit is damaged.	Change the seal kit or cylinder.
Motor does not work.	The motor is burned.	Change the motor after check and confirm that the power is correct.
	The voltage is too low.	Check and confirm that the voltage is the regulated voltage.
	The fuse is burned.	Changed the fuse.
Platform does not lower.	The platform is locked.	Control the platform lift, after lock release, lower the platform down.
	The hydraulic oil viscosity is too big	Change to the regulated hydraulic oil or consult local hydraulic manufacture.
	The plug valve of the power unit is jammed.	Take apart the valve part to wash (pay attention to dust proofing).
	The oil hose or the hose connector is jammed.	Dredge the oil hose and hose connector.
Motor rotate reversely	Wrong wiring	Rewiring according to the circuit drawing.

Check list and periodic maintenance

Inspection period	Points to be checked	Items to be checked	Inspection method	Action to be taken	Replacement period
1 week	Rubber Support for adjustment	Abrasion and deformation	Visual	Replacement	1 year
	Magnetic contactor	Damage of contact	Measurement	Replacement	2 year
3 months	Wire Rope	Abrasion, deformation and Breaking of wire	Visual	Replacement	2 year
			2 months (Use over 20 times per one day)		6 months (Use over 20 times per one day)
	Post Guide	Abrasion	Visual	Replacement	4 year
	DUBush	Abrasion	Visual	Replacement	4 year
	Axle for wire pulley	Noise and abrasion	Visual	Replacement	5 year
	Wire pulley	Abrasion	Visual	Replacement	5 year
6 months	Electrical components	Damage of components	Measurement	Replacement	3 year
	Hydraulic Oil	Shortage of oil	Visual	Replacement	1 year
1 year	Piston Seal Kit	Oil leak or deformation	Visual	Replacement	3 year
	Load Seal Kit	Oil leak or deformation	Visual	Replacement	3 year

APPENDIX

**PART LIST
HYDRAULIC CIRCUIT
ELECTRIC CIRCUIT**

This installation manual is prepared as of October 2016. This manual is subject to change without prior notice if the lift specification is changed.

NOTE

- | | |
|---|---|
| 1 | Bolt assembly of the kind, see the Installation Procedures. |
| 2 | |
| 3 | |

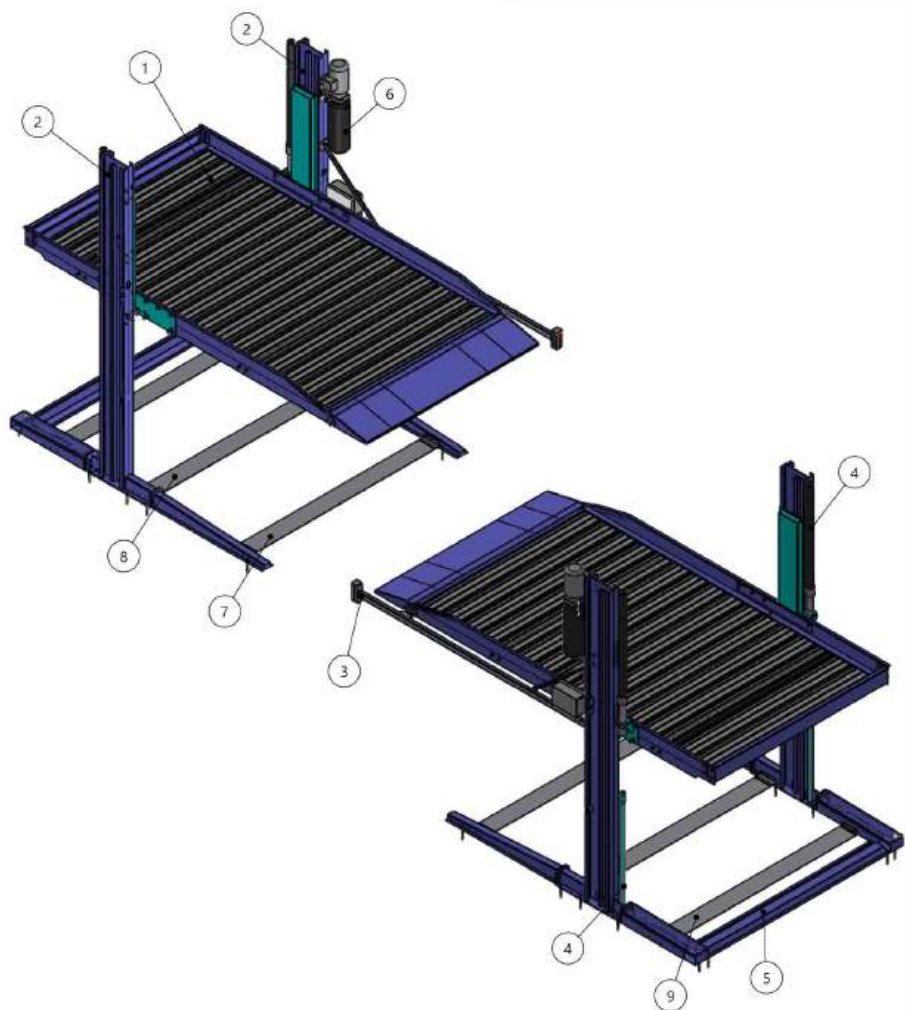

PLATFORM	1	232P4000
POST	2	232P1000
CONTROL PANEL	1	232P2000
CYLINDER	2	232P5000
COVER	1	232P6000
POWERPACK	1	232P7000
BASE GUIDE BAR (1)	1	232P8000
BASE GUIDE BAR (2)	1	232P9310
BASE GUIDE BAR (3)	1	232P8020

NOTE

1 Bolt assembly of the kind, see the Installation Procedures.

2

3

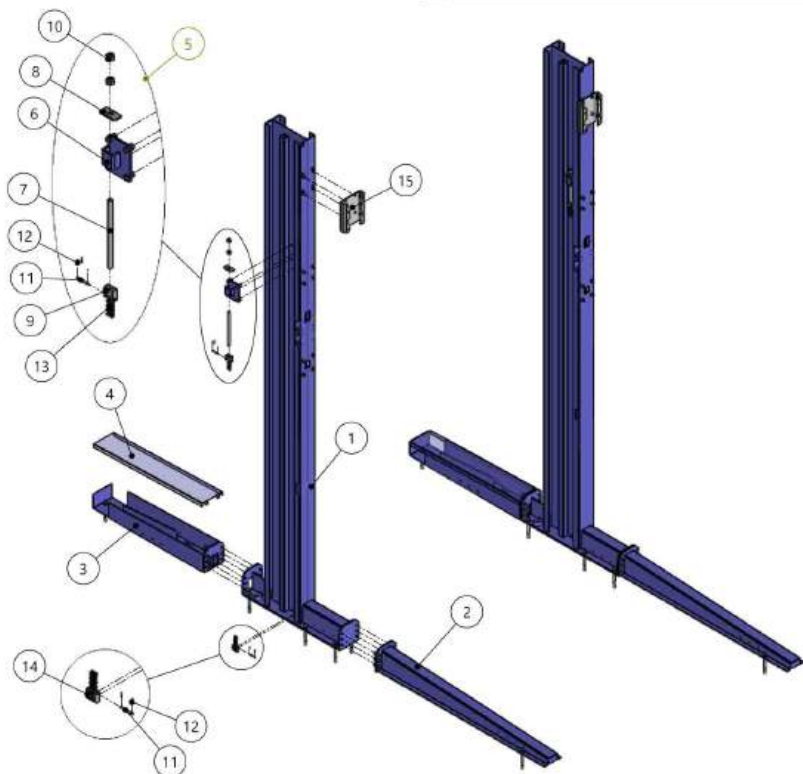

PART NAME(EN)	Q'TY	ITEM NO.
POST	2	232P1010
FRONT BASE	2	232P1020
REAR BASE	2	232P1030
REAR BASE COVER	2	232P1040
CHAIN BRACKET ASS'Y	2	232P1100
SCREW BRACKET	2	232P1110
SCREW	2	232P1120
SCREW FIXED PLATE	2	232P1130
UPPER CHAIN BRACKET	2	232P1140
HEX NUT	2	HNM16
PIN	4	232P1150
PIN	8	PIN0215
CHAIN	2	DBC-BL-544
LOWER CHAIN BRACKET	2	232P1160
POWER PACK BRACKET	1	232P1170

NOTE

1	Bolt assembly of the kind, see the Installation Procedures.
2	Option
3	

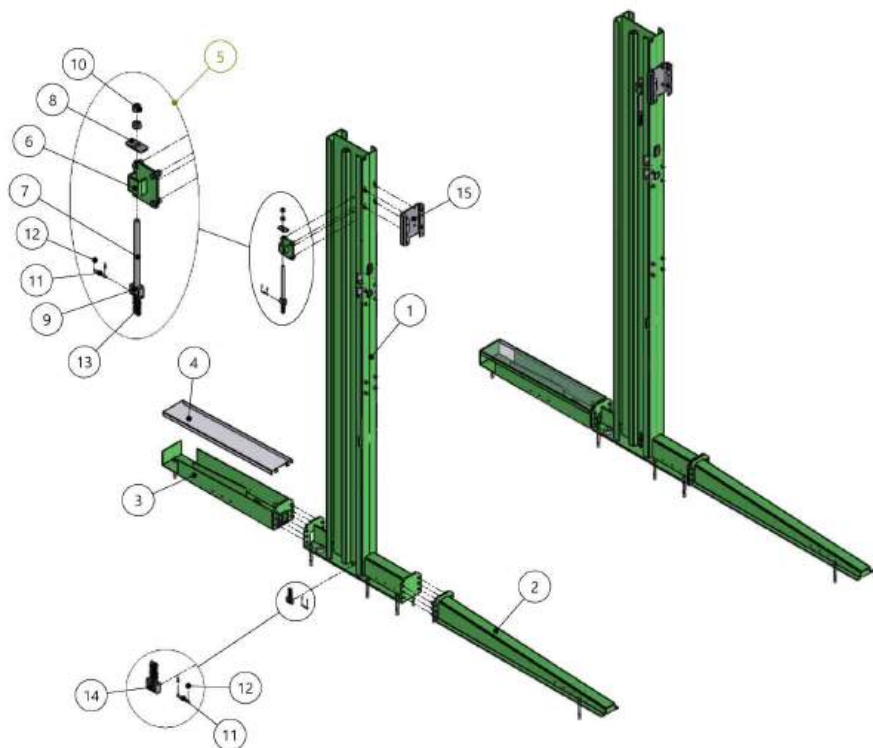

PART NAME(EN)	QTY	ITEM NO.
POST	2	232P1011
FRONT BASE	2	232P1020
REAR BASE	2	232P1030
REAR BASE COVER	2	232P1040
CHAIN BRACKET ASSY	2	232P1100
SCREW BRACKET	2	232P1110
SCREW	2	232P1120
SCREW FIXED PLATE	2	232P1130
UPPER CHAIN BRACKET	2	232P1140
HEX NUT	4	HNM16
PIN	4	232P1150
PIN	8	PIN0215
CHAIN	2	DBC-BL-544
LOWER CHAIN BRACKET	2	232P1160
POWER PACK BRACKET	1	232P1170

NOTE

1	Bolt assembly of the kind, see the Installation Procedures.
2	
3	

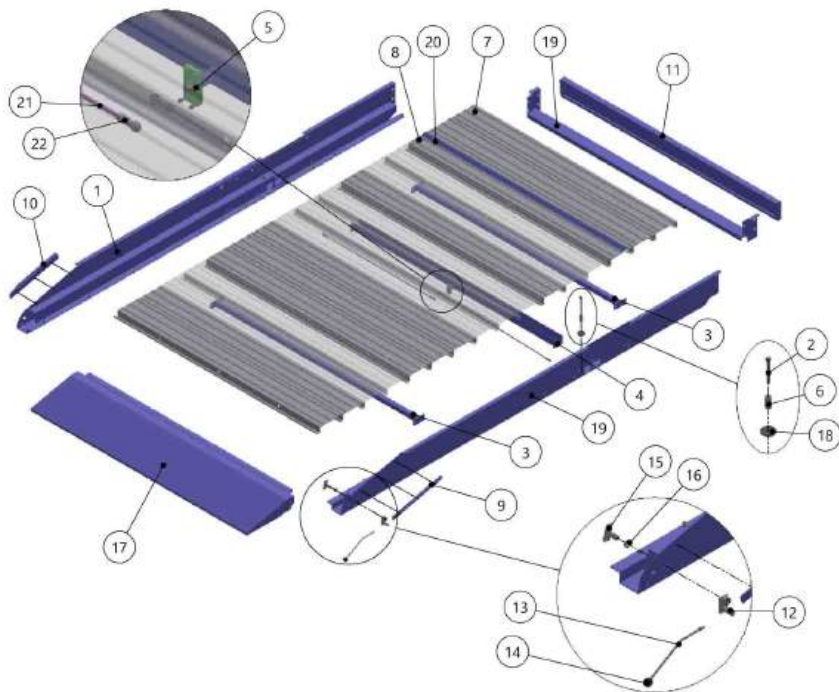

PART NAME(EN)	Q'TY	ITEM NO.
PLATFORM SIDE FRAME	2(TR/1L)	232P4200
HEX BOLT	1	HEXIM12100
PLATFORM LOWER BEAM	2	232P4210
CHAIN SUPPORT	1	232P4260
ROTATE PLATE	1	232P4270
WIRE PULLEY SPACER	1	232P4320
PLATFORM PLATE	15	232P4230
PLATFORM PLATE(1)	1	232P4231
SIDE BRACKET(1)	1	232P4240
SIDE BRACKET(2)	1	232P4250
PLATFORM REAR STOPPER	1	232P4220
LOCKER HANDLE	1	232P4340
LOCKER HANDLE SHAFT	1	232P4345
PLASTIC BALL HANDLE	1	PHANDLE32M12
LOCKER HANDLE SHAFT	1	232P4350
LOCKER HANDLE SPACER	1	232P4360
LAMP	1	232P4300
LOCKER WIRE PULLEY	1	232P4330
PLATFORM STOPPER ADAPTER	1	232P4400
TIRE STOPPER	1	232P4500
UNLOCK WIRE SHAFT	2	232P4280
ROD END BEARING	4	PHSCB_2_03

NOTE

1 Bolt assembly of the kind, see the Installation Procedures.

2

3

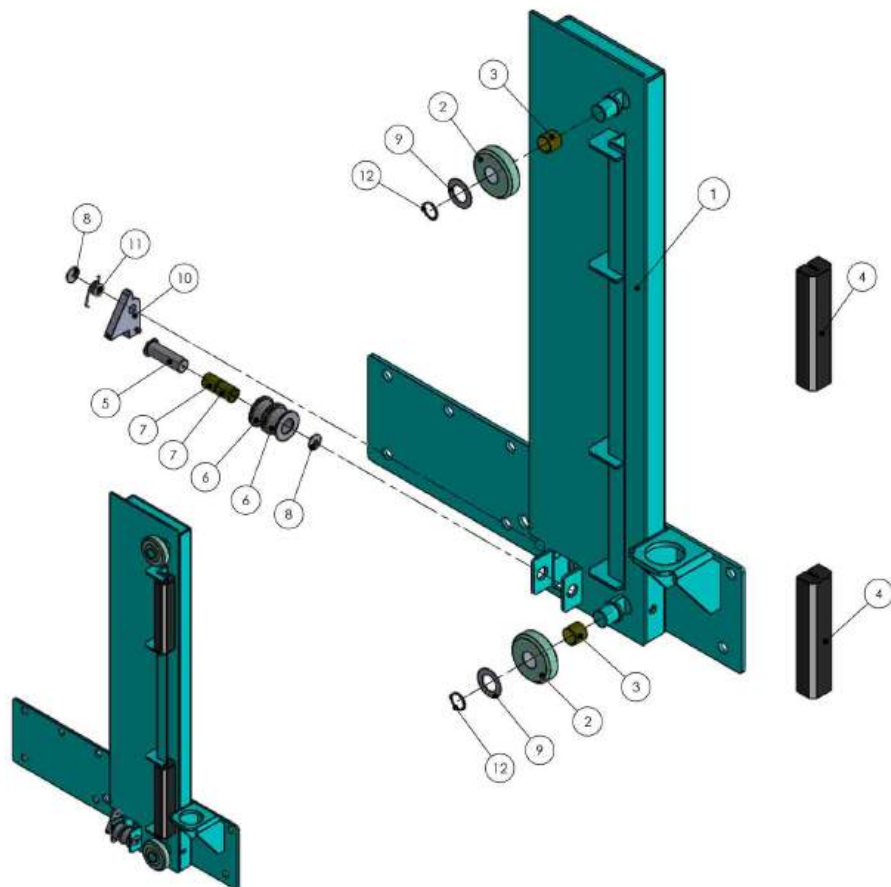

PART NAME(EN)	QTY	ITEM NO.
CARRIAGE	2(1 R/1L)	232P4100
CARRIAGE ROLLER	4	232P4140
DU BEARING	4	DU 3228
PLATFORM SLIDER	4	232P4130
LOWER PULLEY FIXED PIN	2	232P4120
CHAIN PULLEY	4	232P4110
DU BEARING	4	DU 2533
WASHER	4	232P4170
WASHER	4	232P4180
LOCKER	2	232P4150
SPRING	2	232P4160
SNAP RING	4	SN-CS32

NOTE

1 Bolt assembly of the kind, see the Installation Procedures.

2

3

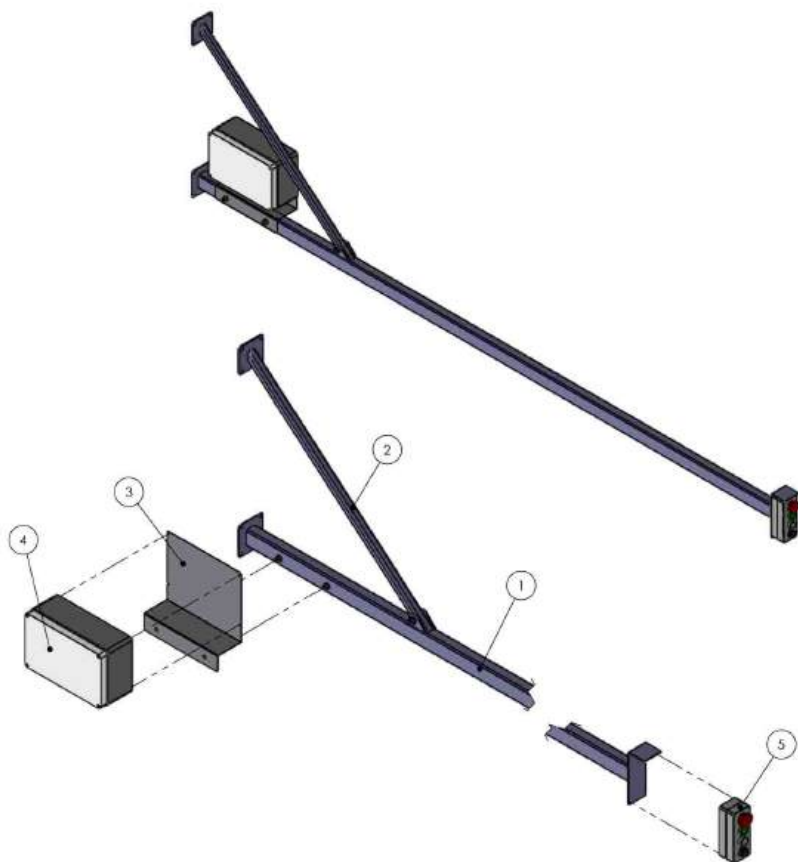

PART NAME(EN)	Q'TY	ITEM NO.
CONTROL PANEL BRACKET	1	232P3010
CONTROL PANEL UPPER BRACKET	1	232P3020
POWER UNIT BRACKET	1	232P3030
CONTROL PANEL	1	232P2100
OPERATING SWITCH	1	232P2200

NOTE

1	Bot assembly of the kind see the Installation Procedures.
2	Option
3	

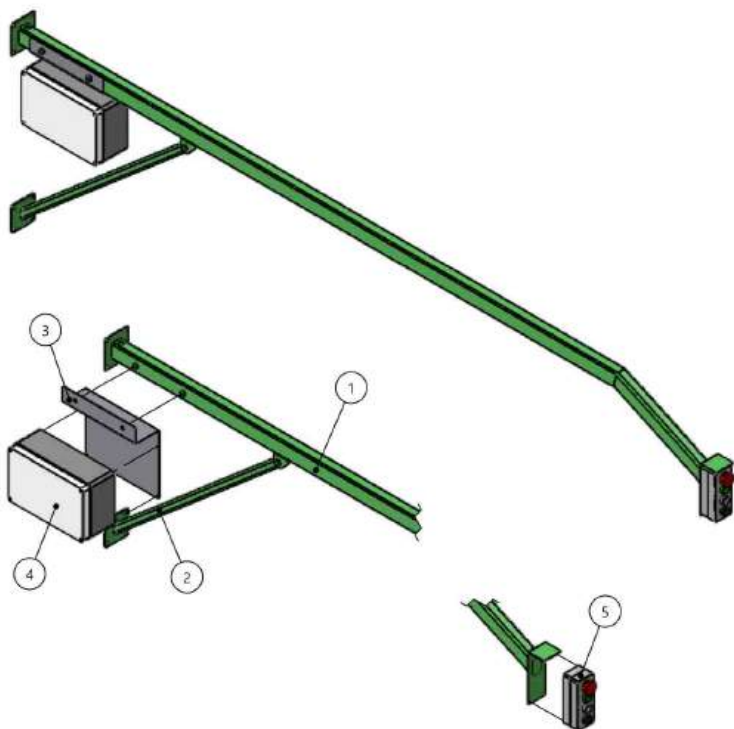

PART NAME(EN)	QTY	ITEM NO.
CONTROL PANEL BRACKET	1	232P3011
CONTROL PANEL UPPER BRACKET	1	232P3020
POWER UNIT BRACKET	1	232P3030
CONTROL PANEL	1	232P2100
OPERATING SWITCH	1	232P2200

MAIN LIFT CYLINDERS
(#60-#45)x21.36ST.

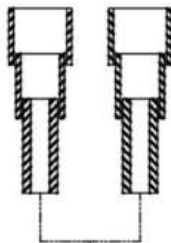

PORT TYPE;
1/4"BSPT(JIS B0203)

A.C MOTOR
4HPx1750RPM (3ph)
(220V/380Vx3øx50/60Hz)

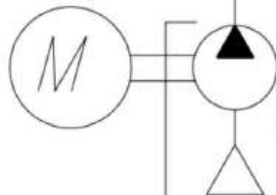

RELIEF VALVE
(190bar SETTING)

GEAR PUMP
(4.8cc/rev.)

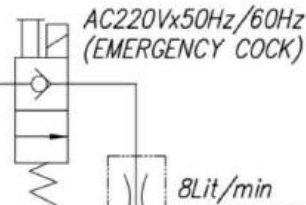

AC220Vx50Hz/60Hz
(EMERGENCY COCK)

8Lit/min
FLOW CONTROL

OVER PRE. RETURN

DRAIN LINE

HYDRAULIC RESERVOIR (14LIT-ROUND&SQUARE TYPE)

