



CITY OF INDUSTRY, CA
BROOKSHIRE, TX
BOLINGBROOK, IL
JERSEY CITY, NJ
POOLER, GA
CONTACT US
SALES: 447-902-3857
TECHNICAL: 716-299-8852
EMAIL: INFO@AUTOKATO.COM



Read the entire contents of this manual before using this product. Failure to follow the instructions and safety precautions in this manual can result in serious injury or death. Make sure all other operators also read this manual. By proceeding with setup and operation, you agree that you fully understand the contents of this manual and assume full responsibility for product use.

TABLE OF CONTENTS

Introduction	4
Features and characteristics	4
Names of each part are described	3
Control pannel	8
Specification	9
Caution Sticker layout	10
Safety	12
Danger/warning/caution	12
Installaion procedures	14
Checklist before installing	14
Place of installation - lay out	15
Check of anything is missing	16
Installation procedures	17
Horizontal control	19
Operation	21
Check points before operation	21
Operation	22
Proper car lift method (the weight setting)	23
Maintenance	25
Equipment maintenance and service	25
Troubleshooting	29
Checklist and periodic maintenance	30
Part List	31

Introduction

Safety

Installation

Operation

Maintenance

Part List

■ This manual was prepared in 2012 the product specifications contained in this manual are subject to change without notice.

Features and characteristics

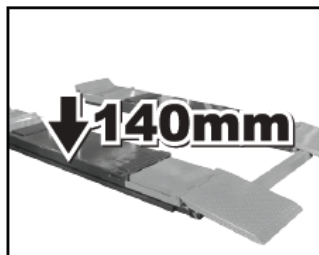
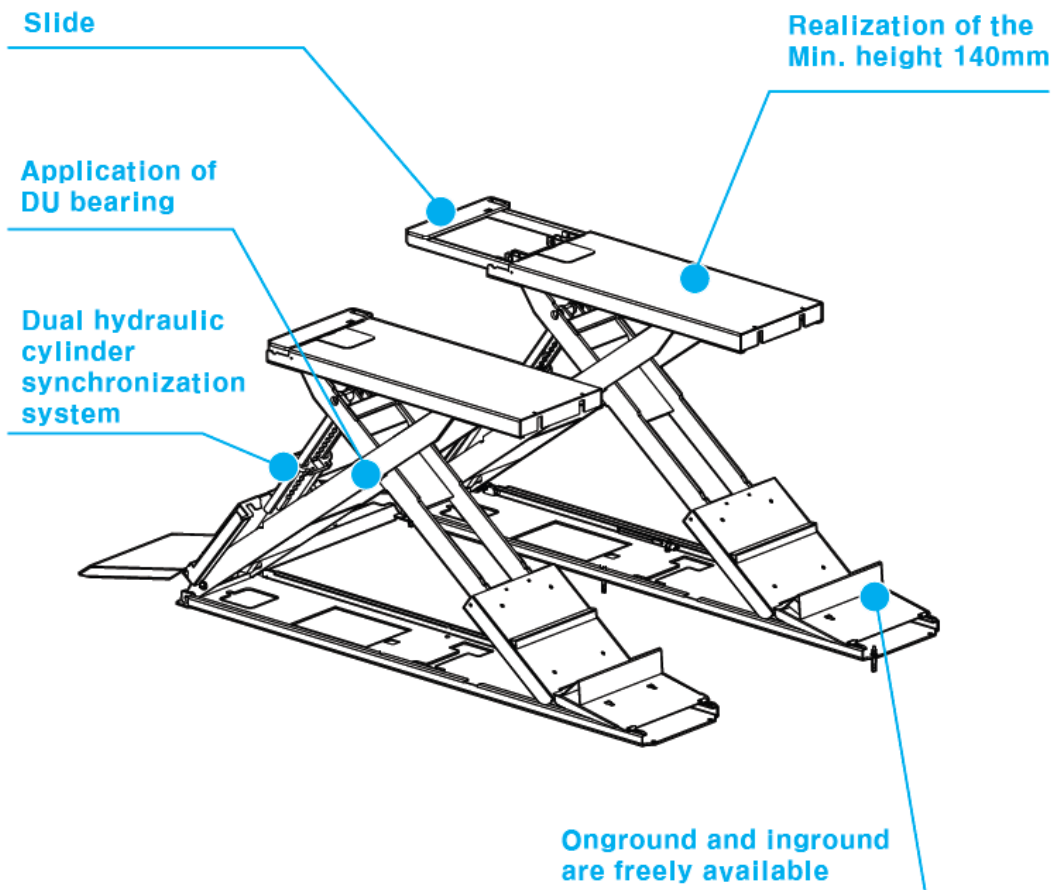

■ Realization of the lower ground lift

► Cars are entered easily and minimize lift drop accident from minimum height 140mm realization.

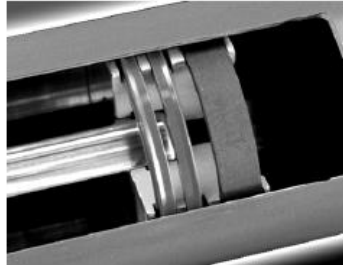

■ Double high-pressure seals

▶ Powerful hydraulic cylinder with double u-packing seals.



■ High performed upper roller

▶ DU bearing in roller for reducing noise and durability.

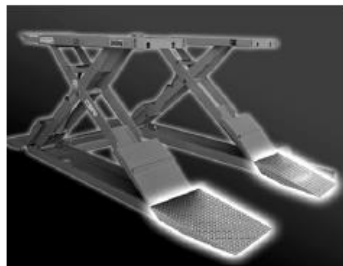

■ Onground and inground are freely available

▶ As workshop situation, freely change types.

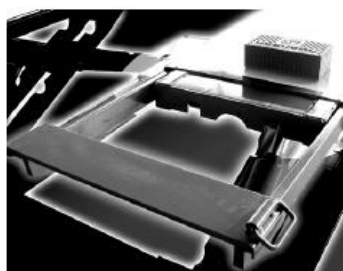

■ Slide of platform

▶ Slide bar is applied to the platform for van or longer vehicle.



■ Dual hydraulic cylinder synchronization system

▶ Use four cylinders for synchronization performance.

Names of each part are described

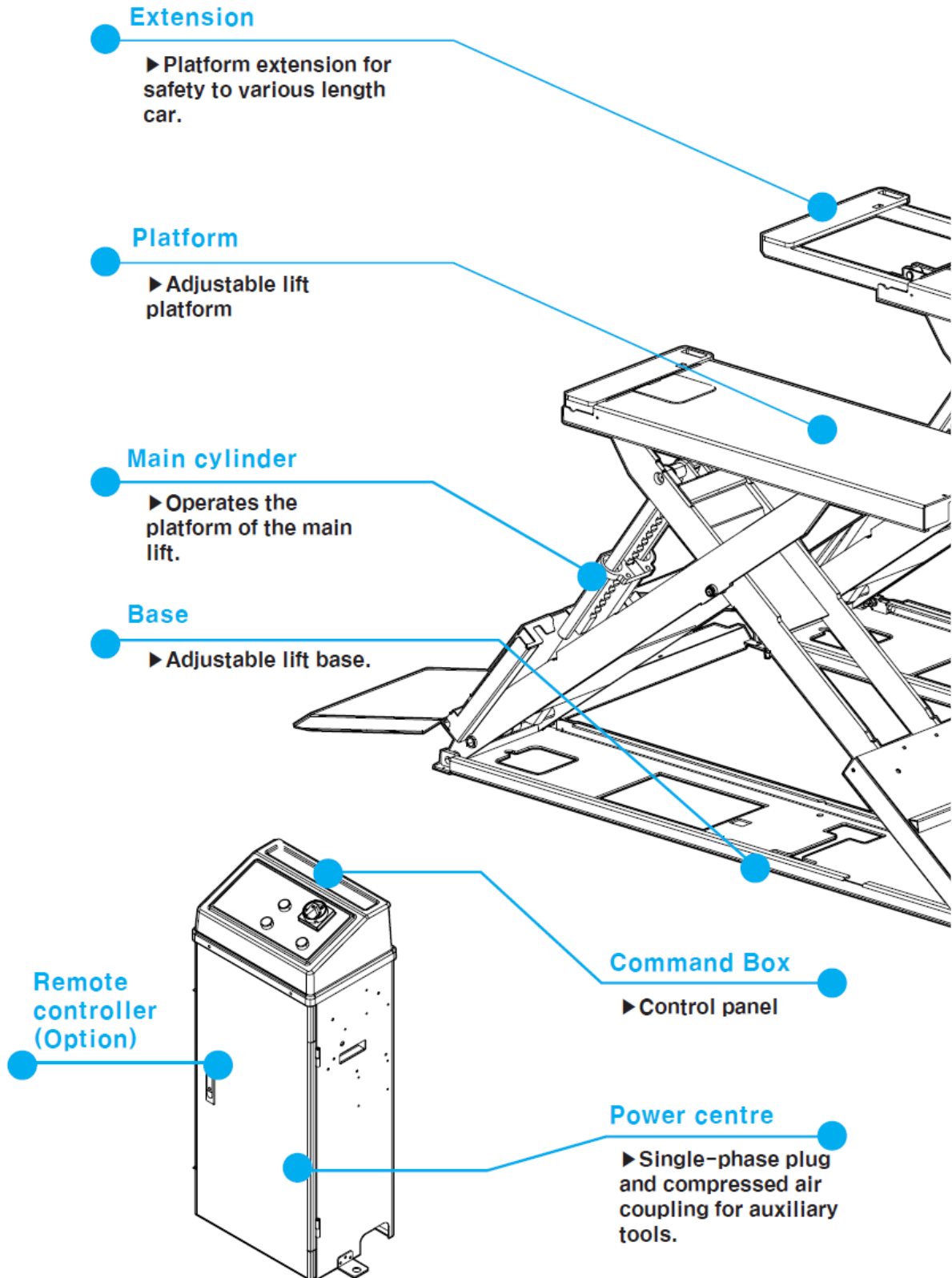

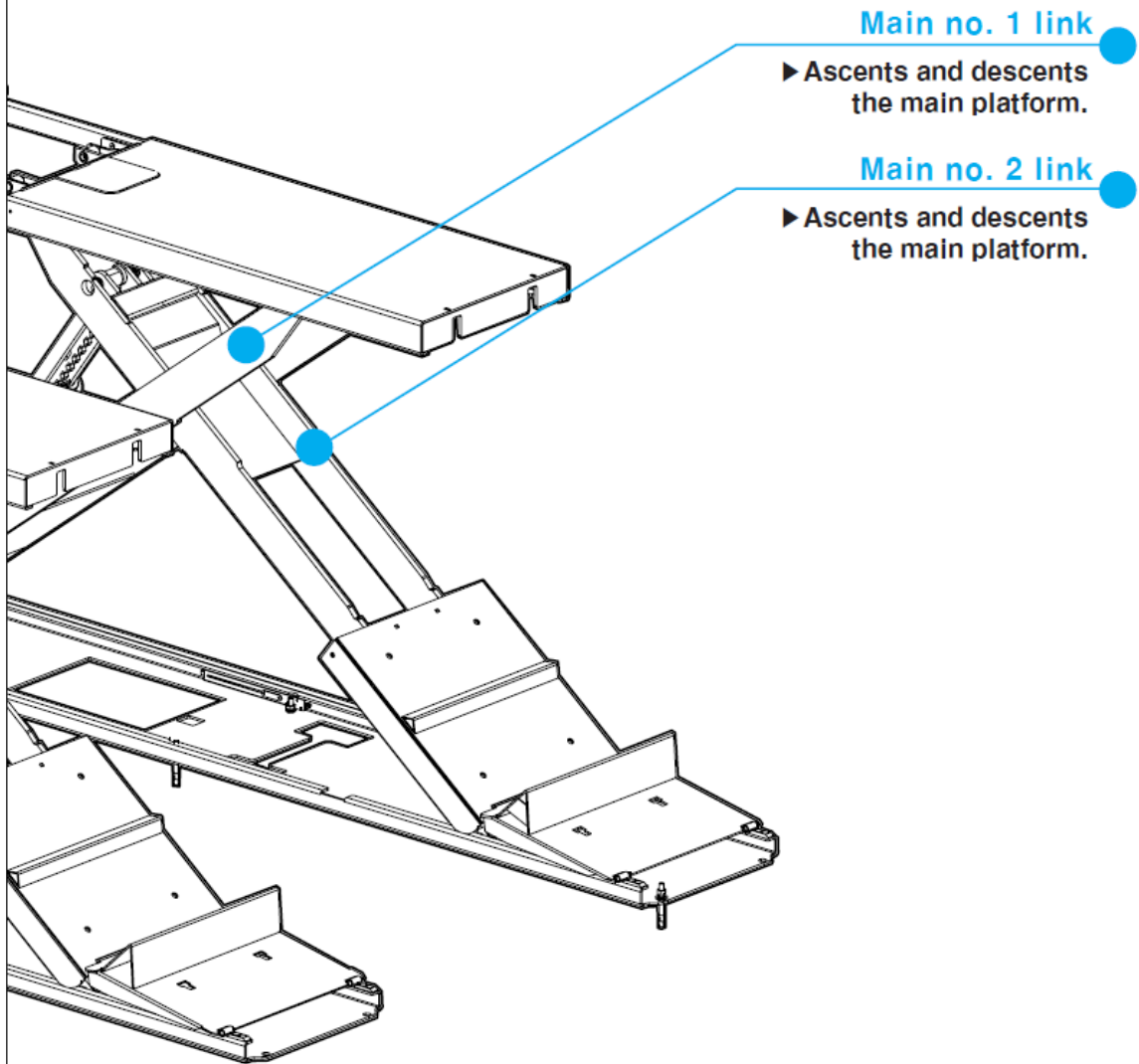

See page "PARTS LIST"



Control panel

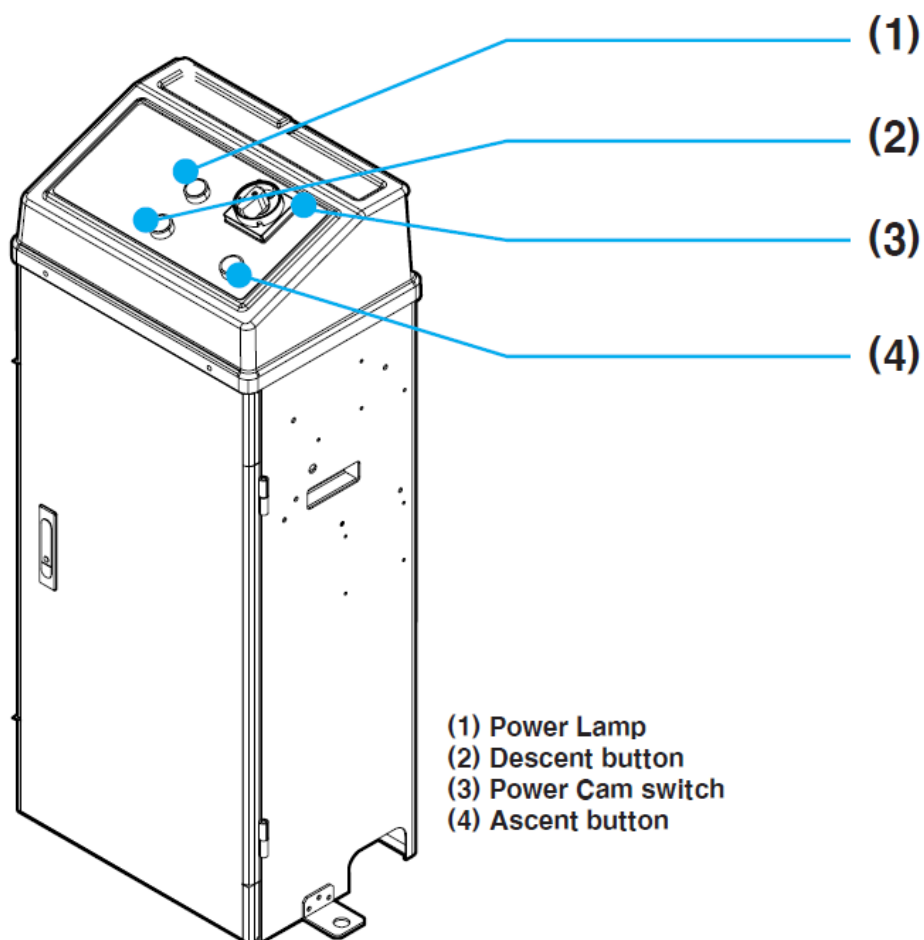

- (1) Power Lamp
- (2) Descent button
- (3) Power Cam switch
- (4) Ascent button

- (1) Power Lamp
- (2) Descent button - Descends the main platform
- (3) Power Cam Switch - Supply or isolate the power of the lift.
- (4) Ascent button - Ascends the main platform

Specification

Capacity	3500kg
Used Hydraulic Pressure	250 Kgf/cm ²
Overall Max.Height	1940mm
Min.Runways Height	140 mm
Stroke	1,813 mm
Lifting Time	Approx. 55 ~ 65 sec
Lowering Time	Approx . 50 ~ 65 sec.
Standard Motor	1ph 2.5HP 220V 60Hz / 3ph 2HP 220,380V 60Hz
Net Weight	1,050 kg
Layout Dimension	3,841 × 140 × 2,065 mm



enjoy repairing



Caution Sticker layout

Caution/Warning/Danger





Lift

Capacity



enjoy repairing

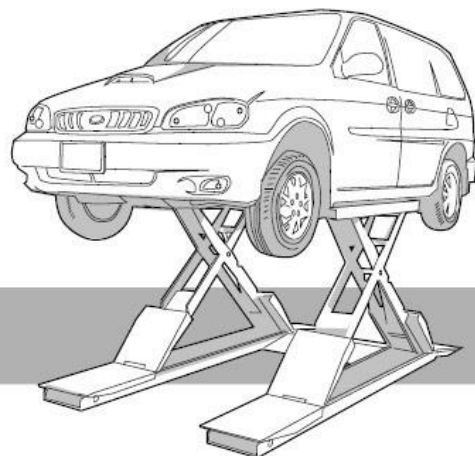

Precautions for safety

Danger/warning/caution

Rules for illustrations
in the Manual.

These are the
rules for the
illustrations in the
manual. Make sure
that you read and
understand
them. The rules
are applied only
to the manuals



Make sure you follow the instructions,
otherwise critical injuries can occur.



Make sure you follow the
instructions, otherwise critical
injury or damage can occur.



Make sure you follow the
instructions; otherwise, injury or
damage can occur



The terms are described to enhance
the understanding of the equipment.



Information to use the equipment
efficiently.



Precautions or check points for the
use of the equipment.



Please refer to the page



Do not come
under the vehicle
during operation.
▶ It may cause
severe injuries.



Evacuate to a safe
place instantly in
the event that the
vehicle tips.
▶ It may cause
severe injuries.



Do not overload
the rated capacity.
▶ It may cause
severe injuries.



※ Not following
the instructions
can lead to a
critical accident
involving your
life. Make sure
you follow the
instructions.



Warning before using the equipment

Only trained
personnel may
operate the
equipment.
Inexperience can
cause accidents.



Position the
vehicle to make
sure that it is
balanced front
and rear, right and
left (otherwise the
vehicle may fall
off).

















Do not operate
damaged equipment
(a critical accident
could occur -
contact your
supplier)



After that a
vehicle is placed
on the lift make
sure that the hand
brake is applied.
Passenger
transport is
forbidden.

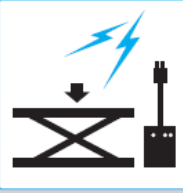

Precautions for safety

 Warning	Warning while operating			
<p>Allow no unauthorized persons in the work area.</p> 	<p>Before lowering the lift, check that there are no obstructions under the vehicle or the lift arms.</p> 	<p>When the vehicle is lifted, do not rock it as this may dislodge it.</p> 	<p>Do not lift a vehicle using one pair of arms only.</p> 	
 Warning	Warning while operating			
<p>To avoid injury, keep your feet clear of the arms and carriages.</p> 	<p>Before going under the lift, make sure that the safety pawls are engaged.</p> 	<p>To avoid being electrocuted, disconnect the main power before opening the control panel.</p> 	<p>Do not modify the control panel or the safety functions as this may impair their function.</p> 	
 Caution	Warning when operating	Warning before using the equipment		
<p>Do not rock the vehicle when lifted. Do not use a high pressure cleaner as the vehicle lower part.</p> 	<p>Read and fully understand the manual before using the lift</p> 	<p>Check the safety devices to see that they are clean and operable.</p> 	<p>If the lift is idle for a long time, disconnect the main power supply. In the event of thunder storm, disconnect the main power supply.</p> 	

Checklist before installing

Installation site

The site must be flat and horizontal. The floor must have minimum 160mm depth of reinforced concrete.

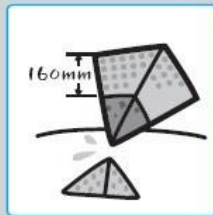

Surface load under the posts must be minimum 25N/mm².



To maintain the warranty, the lift is intended for indoor installation only. In the event that it is installed outside it should be protected from snow and rain. Outdoor installation makes the warranty invalid.



Installation site

Ambient temperature 10°C to 50°C. Do not operate under freezing conditions.

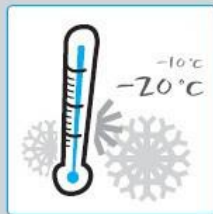

Vehicle access to the lift must be safe and easy.



There must be a safe working distance of minimum 1m between the lift and the wall or any fixed object.

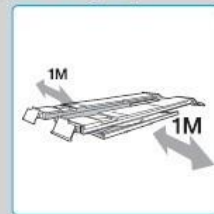

Installation site

To ensure that the anchor is secure, the hole for an anchor bolt must be more than 2/3 of the bolt length.

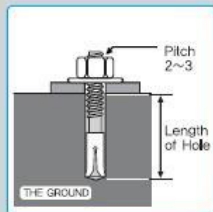

Skilled engineers sale representative agency shall install the lift, otherwise a failure may occur.



Please contact head office or distributors for the removal of lifts.



Place of installation (Layout)

Check points before selecting the place of installation

- ① Distance from the wall or any fixed object
- ② Drive-on direction
- ③ Position of power post and slave posts
- ④ Ceiling height

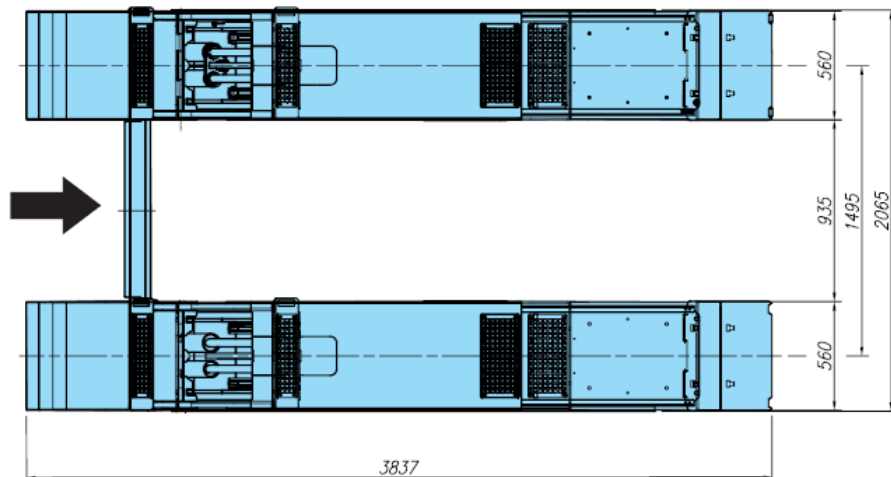
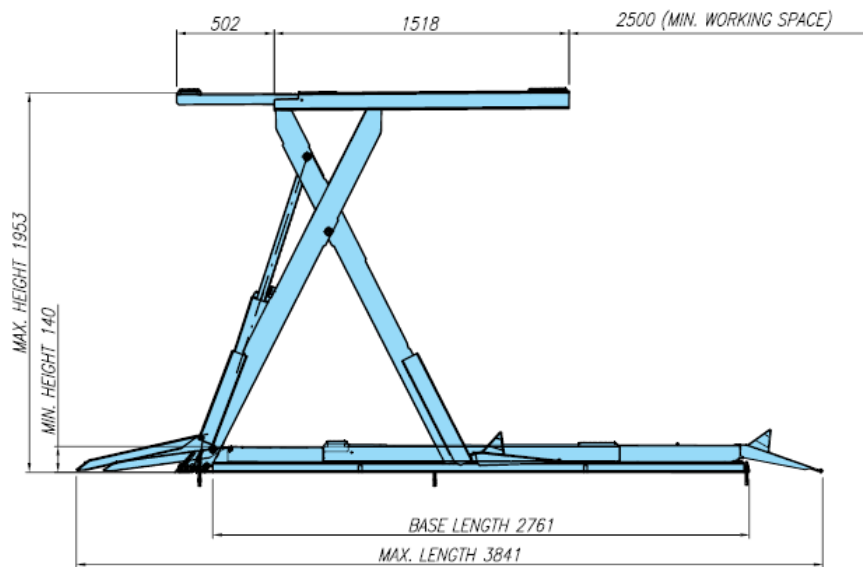

■ Check the items

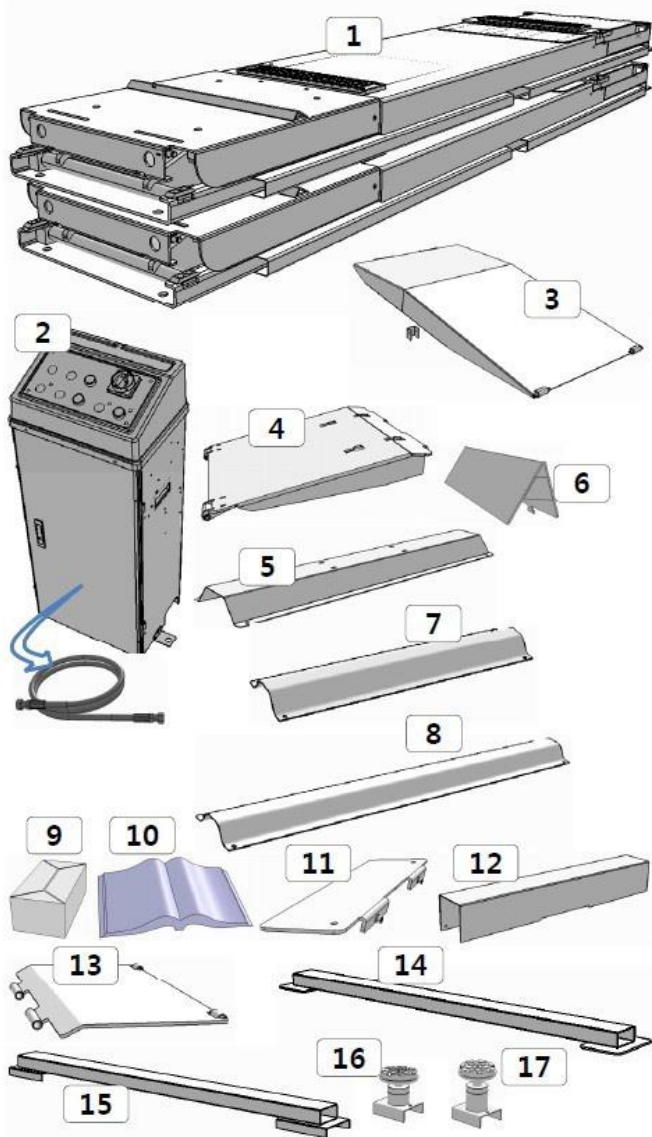

(Ground type)

1. Main body
2. Control panel : 1 unit
3. Entrance plate at front side (Ground type) : 2 unit
4. Entrance plate at rear side (Ground type) : 2 unit
5. Synchronization cover (Ground type) : 1 unit
6. Stopper at rear side (Ground type) : 2 unit
7. Hose cover1 : 1 unit
8. Hose cover2 : 1 unit
9. Component box for shipment : 1 unit
10. Manual : 1 unit

(Inground type)

1. Main body
2. Control panel : 1 unit
9. Component box for shipment : 1 unit
10. Manual : 1 unit
11. Entrance plate at front side (Inground type) : 2 unit
12. Hose cover (Inground type) : 1 unit
13. Entrance plate at rear side (Inground type) : 2 unit

(Option)

14. Extension beam SET-1 (1 unit)
15. Extension beam SET-2 (1 unit)
16. Extension beam SET-3 (2 unit)
17. Extension beam SET-4 (2 unit)



Check the items : If any of these items is missing from the box, contact your sales representative. **Preparation for installation :** Deploy the items in the installation site as specified in the layout. Check the positions of power and slave posts, drive-on direction, safe working area.

Installation procedures

■ Landing down the product at the place to be installed

- ▶ Place the lift main body at the place to be installed referring to layout document.
- ▶ Fixing the product after checking the caution notes.

In case of the forklift use

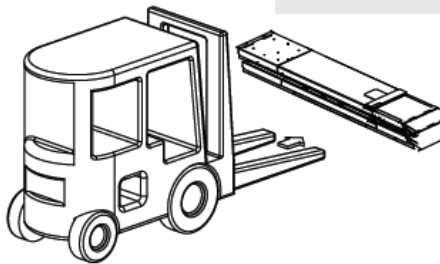

In case of the crane use

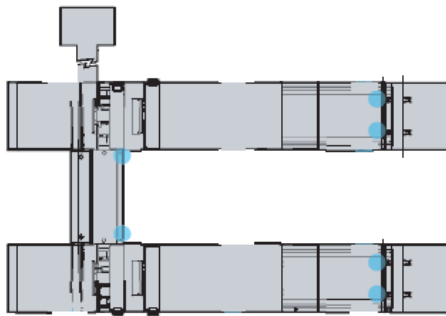
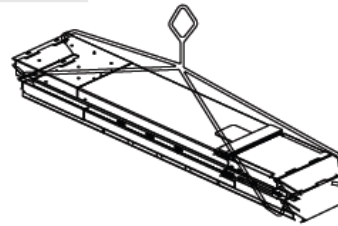

■ Fixing the base with anchor bolt

- ▶ Fix the 6pcs Anchor bolt of the base plate and 2pcs Anchor bolt of the control panel after supporting lift using liner.

■ Fixation horizon of the base

- ▶ After adjust horizon of the product precisely, fix up using anchor bolt.

1 Adjustment the level of the base.

After measure the horizontal status, lay down the lie.

2 Fixation of base (anchor)

After adjust the level, fix up the base platform using anchor.

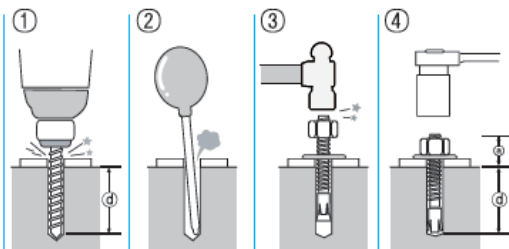

Anchor bolt installation.

- ① Drill a hole (∅: hole depth)
- ② Clean the inside of the hole
- ③ Put the anchor bolt into the hole and hammer in until it reaches the bottom of the hole
- ④ Tighten the bolt with a spanner.
(∅35~45mm)- Torque : 80~100N.m

■ Connection of oil pressure hose

► Connect oil pressure hose by referring oil pressure line diagram. (Refer to part list oil pressure circuit)

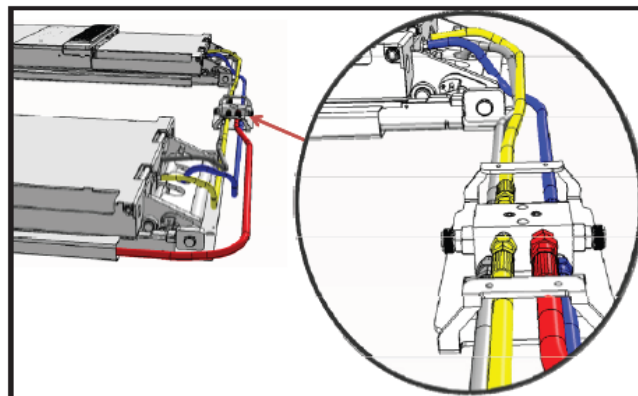
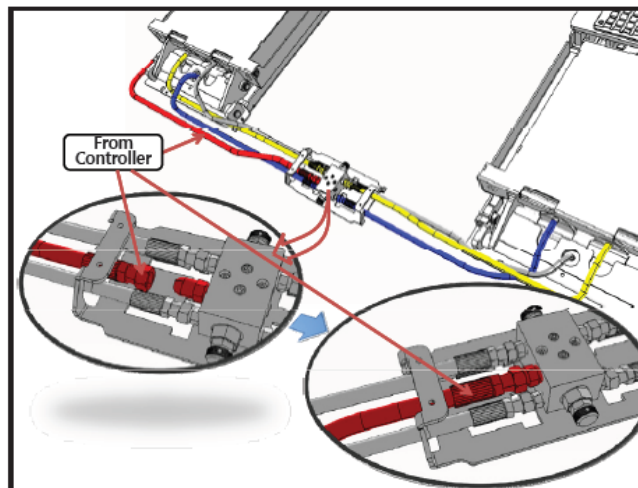
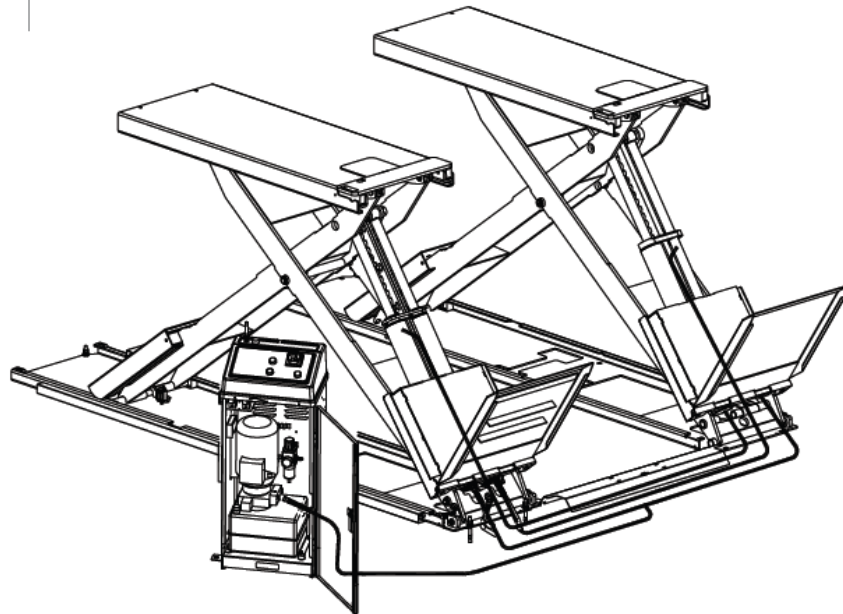

How to level adjusting (unloaded) – Use by user

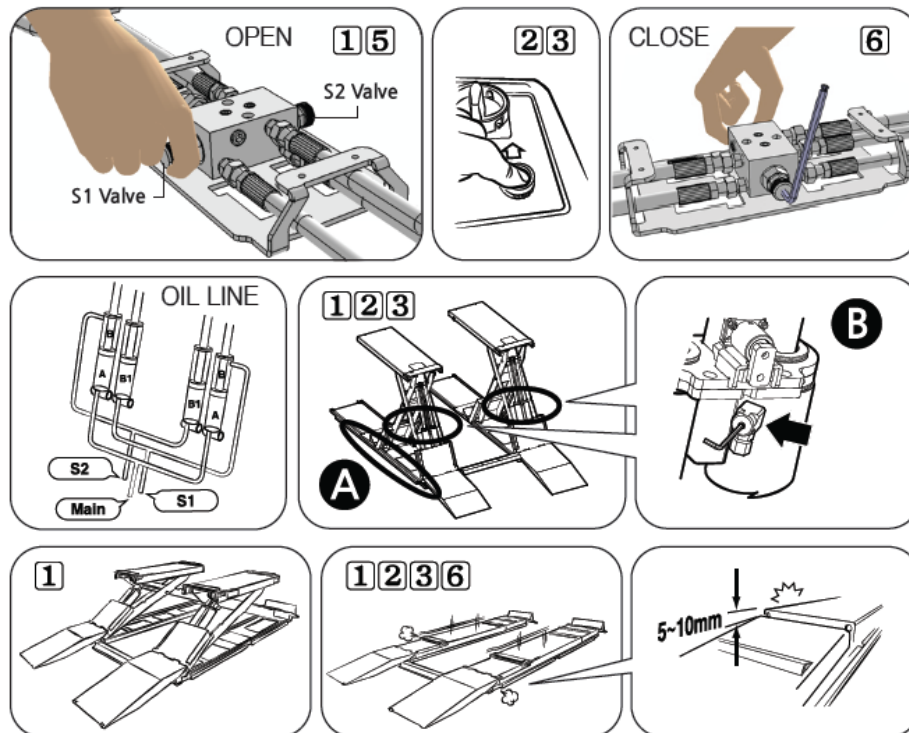

1 Horizontal control

1. Descend to bottommost position and continue to push the down button again fully after opened the valve "S1,S2".
2. Push the ascending button like short time clicking several times for filling oil to 20~40mm gap height. Descend again.
3. Once again, click the ascending button for a short time several times for filling oil until beginning time of the moving board (platform).
4. Descend again to bottommost.
5. Next, still to be opened "S1,S2 valve", push the ascending button for a short time several times.
6. (Important) at this time with No.5, at the moment to be started moving up the board(5~10mm) with leveled both boards, close the both valves(S1,S2) tightly at the same time. Finish.



► If maintaining level is not well achieved with vehicles on the lift, after-sales service is strongly recommended. Self-operating by customer is heavily dangerous. Our company is not responsible for any accidents that occur from this case.



► Any operations other than what is introduced in this manual are supposed to be handled with other service instructions. Any accidents coming from manipulation of manual above is out of company's responsibility.

How to level adjusting (unloaded) - Service man

- After changing the cylinder or oil hose

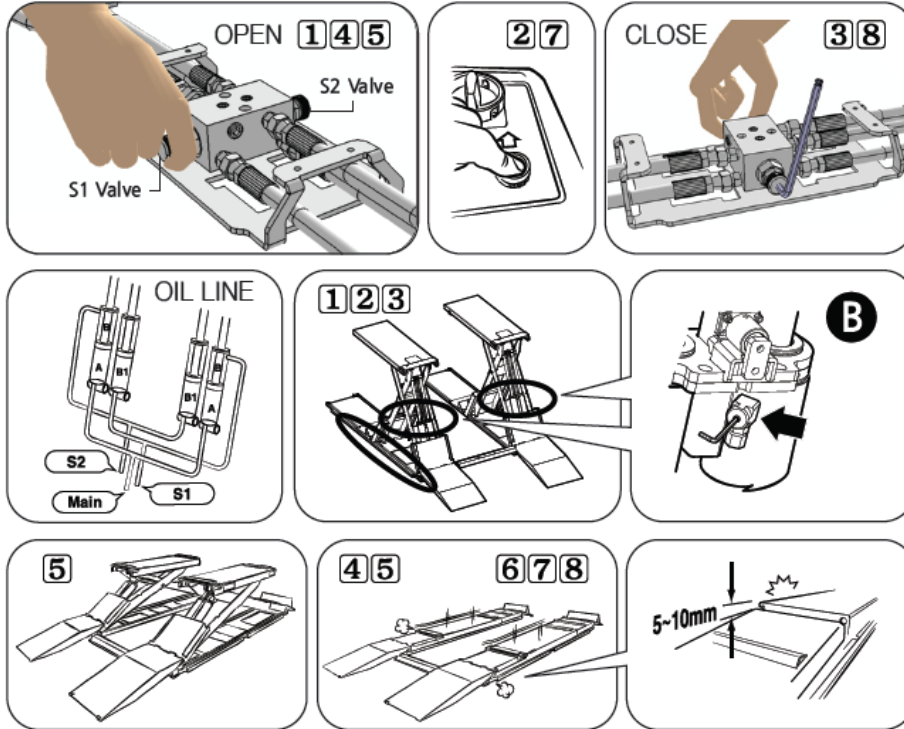

1 Horizontal control

1. First, bleed the air inside of cylinder and oil line after filling the oil.
2. Ascend the board to the topmost position after release the limit switch "A". Unscrew the "B", and push the ascending button for bleeding.
3. Push the ascending button several times, and screw the "B" tightly.
4. Descend to bottommost position and continue to push the down button again fully after opened the valve "S1,S2".
5. Push the ascending button like short time clicking several times for filling oil to 20~40mm gap height. Descend again.
6. Once again, click the ascending button for a short time several times for filling oil until beginning time of the moving board (platform).
7. Descend again to bottommost.
8. Next, still to be opened "S1,S2 valve", push the ascending button for a short time several times.
9. (Important) at this time with No.5, at the moment to be started moving up the board(5~10mm) with leveled both boards, close the both valves(S1,S2) tightly at the same time. Finish.



► If maintaining level is not well achieved with vehicles on the lift, after-sales service is strongly recommended. Self-operating by customer is heavily dangerous. Our company is not responsible for any accidents that occur from this case.



► Any operations other than what is introduced in this manual are supposed to be handled with other service instructions. Any accidents coming from manipulation of manual above is out of company's responsibility.

Check points before operation

Before loading the lift, check the following points.

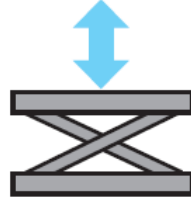

■ Test operation

▶ Operate ascent and descent 2~3 times under no load condition.

■ Switch operation

▶ Check that the ascent and descent push buttons are working correctly.

■ Hydraulic check

▶ Check if there are no hydraulic leaks from either cylinders, pipes, or hose joins.



■ Mechanical check

▶ Check the tightness of all nuts, bolts, etc.

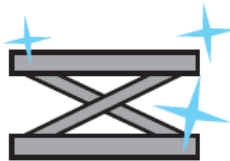

■ Exterior check

▶ Check the exterior of the lift to ensure that there is no obvious damage.

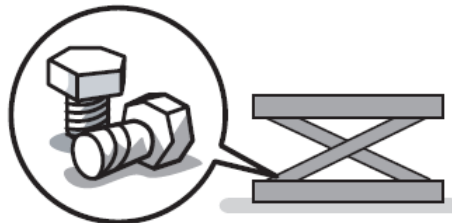

■ Cleanliness

▶ Check every day that the lift and the work area are clean and free from debris or obstructions.

Inspect the lift everyday to operate the lift safely for a long time.

Operation

1 Prior to use

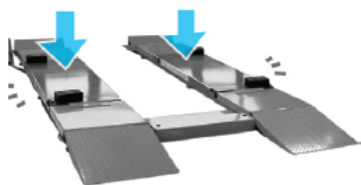

Check that the platforms are parked at floor level by using the descent button. Check that the auxiliary lift is at the down position.

2 Prior to vehicle entry

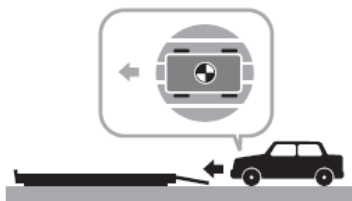

Check that the position of the righthand (movable) platform is suitable for the majority of the vehicles to be lifted. Fix the platform at this position with the bolts provided.



Attention before you enter



Remove the humidity of the tire before you enter.



Attention the sudden stop.



After you drive into the lift, hold the side brake.



After you drive into the lift, get out of the car.

3 Lift up the lift to the second descent position

Press the ascent switch, and lift up to the 140mm height. Extract the platform slide plate at the 140mm height and adjust position to be lifted safely. (use rubber support)



4 Vehicle repair

Perform the necessary repairs and/or maintenance on the vehicle. After completion, lower the auxiliary lift. As soon as the vehicle load is firmly on the platforms, stop the descent of the auxiliary lift, remove the rubber pads, push in the extensions, and lower to bottom position. Lower main lift.

5 Descent lift



Press the decent switch and descend to the position (140mm height), and return the platform slide plate to the original place, and descend to the bottom postion.

► Extract the car after checking it is descended to the bottom place completely.

Proper car lift method (the weight setting)

■ Proper weight setting method(3-ton standard)

► Using the proper car weight setting method, lift would be maintained safely. This guide follows the Europe CE standards.

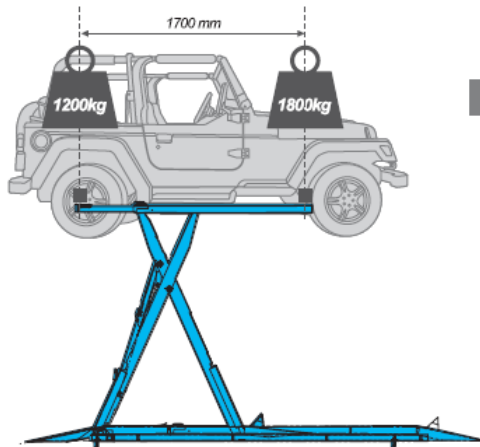

1 Entering from the front side

► Set the weight front/rear platform, each ratio 3:2
3/5 region is 1800kg, 2/5 region is 1200kg, total 3000kg setting is possible.

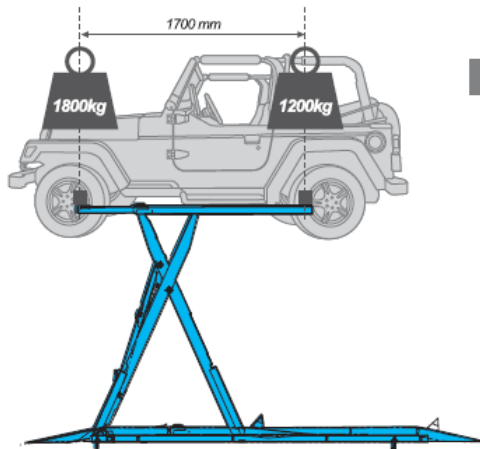

2 Entering from the rear side

► Set the weight front/rear platform, each ratio 3:2
3/5 region is 1800kg, 2/5 region is 1200kg, total 3000kg setting is possible.

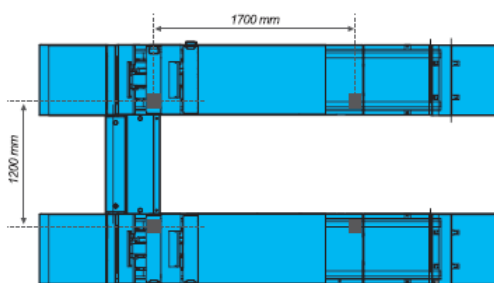

3 Put the rubber plate on the proper position.

► Place the rubber switch on 1700mm X 1200mm region corner.
(Any place inside the 1700mm X 1200mm, cars are lifted safely)



► This guide show the normal standard.
Following the car vendor, model, position of the engine, this guide would be modified.

MEMO

Equipment maintenance and service



▶ Periodic grease and oil injection maintain the product to be safe.



■ Lubrication

▶ Grease or oil should be applied every 2 or 3 months to the parts shown below.

1 Injecting grease

▶ Inject enough grease at shaft of auxiliary lift and roller. (2~3 months period)

2 Injecting oil

▶ Location of injecting lubricating oil
- Paint the lubricant oil to the rubbing surface, base platform every 2~3 months.

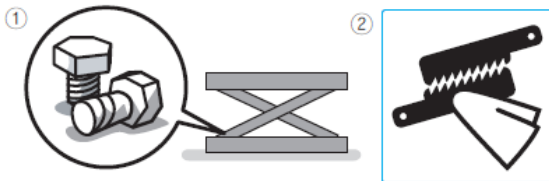

■ Cleanliness

① Check the working area under and around the lift for cleanliness. Check visibly if any nuts or bolts are loose or missing. Replace and retighten as necessary.

② Safety devices
Check the area around the safety devices for cleanliness and any obstruction.

■ Check the snap-ring of the link axis

▶ Check the existence of the inside and outside of the link axis.

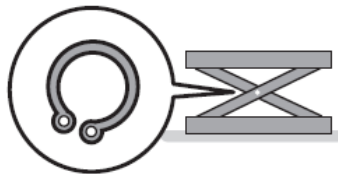

■ Auxiliary lift platform extensions

► Check that the rear extensions can be adjusted throughout the full length of their travel without obstruction. Check that the stop bolts at full travel are in place and are tight. Check the surfaces of the extension arms for wear.

■ Emergency descent

How to descend the lift manually in emergency

1

It is necessary

- ① When a blackout or the hydraulic circuit failure occurs
- ② When the lift cannot descend as specified in the troubleshooting.

Preparation before operating

- ① Remove any object under the lift.
- ② Turn off the main power switch and panel power switch.
- ③ Manually release the locker In case of locking state, releases the locker while another hydraulic device is lifting the locker 30 mm high.
- ④ After taking to pieces in manually, put the supports between lockers.

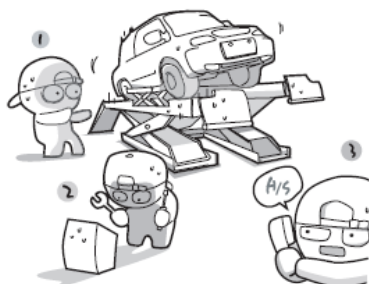

This situation is potentially very dangerous. This operation should not be undertaken by unskilled staff. Therefore, if in any doubt, call your lift supplier immediately for after sales service.

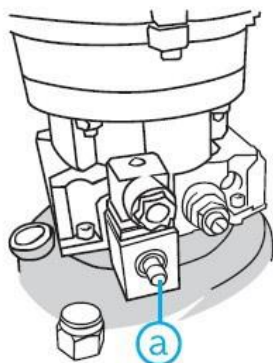

Operation procedure of manual descent

Remove the cover of the powerpack. Remove the solenoid valve hexagon cap (19mm) in the middle of the pump manifold.

Turn the emergency cock lever (a) very slowly anti-clockwise. Too much movement will increase descent speed too much.



Turn the emergency cock lever very slowly to ensure that descent speed is slow and safe, especially if there is a vehicle on the lift.

Steps after completing the operation

► Turn the lever clockwise and lock it securely when the lift reaches bottom position. Replace and refit the hexagon cap. Request after sales service to check the lift.

2 Powerpack pressure



The pressure is set by the factory. The lift may be damaged if the operator increases the pressure. If the equipment does not lift the rated capacity, contact your lift supplier for engineer assistance.

Information for the authorized service engineer only

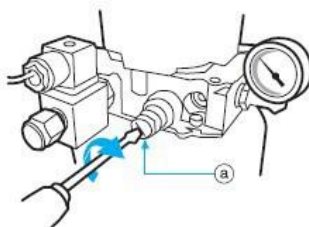

Open the control panel and install a pressure gauge in the pump manifold as shown. The pressure adjusting screw (a) is sealed by the factory. Remove the seal and adjust the pressure with a screwdriver. This should be done while pressing the ascent button at the same time and with the lift loaded with the full rated capacity.

Proper pressure by model _____

250 Kg/cm²

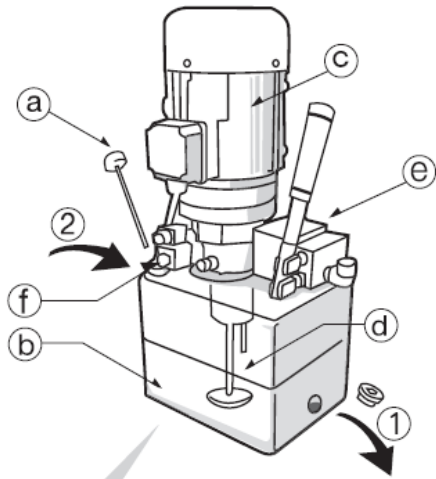

- | | |
|----------------------------------|-----------------|
| a Cap of the oil tank | 1 Oil injection |
| b Oil tank | 2 Oil discharge |
| c Cover of the hydraulic unit | |
| d Pump filter | |
| e Emergency manual pump : option | |
| f Emergency cock | |

3 Oil change

Oil should be changed 3 months after installation and thereafter annually.

Oil change procedure

- ① Remove the cover of the hydraulic unit.
- ② Remove the oil filter cap and dipstick. Carefully remove the oil drain plug and allow the oil to discharge into a suitable container.
- ③ Refit the drain plug and tighten.
- ④ Refill the oil tank with new oil.
- ⑤ Check with the dipstick that the level is correct, raise and lower the lift and recheck that the level is still correct. If not, top up with oil.
- ⑥ Refit the cover.

4 Emergency manual pump operating

In case of the emergency situation you cannot use the electric operation, you can use manual hand pump "e" for emergency descent.

You can shake lever "e" repeatedly, then you can see that the Lift goes up slightly. Next, you should release the safety locker.

then you can descend manually with unscrewing the emergency "f" cock(check valve).



At the annual oil change, after having drained the oil tank, remove the oil tank from the pump and check the condition of the pump filter.

Clean or replace as necessary.

Replace tank and follow the above procedure.

Troubleshooting

	Symptoms	Check point	Corrective Action to be taken
Hydraulic cylinder and its units	The abnormal noise at motor is hearable,	1. Rated capacity is exceeded. 2. Relief pressure is low. 3. Shortage of hydraulic oil.	1. Operate within rated capacity. 2. Adjust to 3 ton. 3. Let air out of the hydraulic unit after supplying the oil.
	Hydraulic Oil is leaked.	1. Defect in hydraulic hoses. 2. Leakage from connecting parts. 3. Bad cylinder packing.	1. Replace the hydraulic hose. 2. Tighten the connection. 3. Request A/S.
	Oil is contaminated.	Check if water or foreign substance comes into the cylinder,	Exchange oil (annually) (Hydraulic oil: 32CST/12litter)
	The lift is not moving up.	Check if the oil is leaked or hydraulic pump are damaged.	Request A/S.
	The lift is not lowering.	Check if the valve is properly operated.	Request A/S.
	The fitting parts is rusted.	Check if the grease is not sufficiently injected.	In jet the grease every 1 month.
Electric Devices	Motor is not operating and the abnormal noise at the motor is hearable,	1. Check if the motor is damaged. 2. Check if the fuse is opened. 3. Check if the push button is damaged. 4. Check if the upper limit is operated. 5. Check if wiring gauge is proper. 6. Check if the input power less than 200V is supplied.	1 Replace the motor (Request A/S). 2. Replace the fuse after solving trouble. 3. Replace the push button (Request A/S). 4. Re-operate after lowering the lift. 5. Replace to the cable with over 3.5mm ² diameter. 6. Increase the input power capacity.
	Fuse is snapped	1. Check the contact of magnetic contactor. 2. Check the capacity of circuit breaker. 3. Check if the wire is damaged.	1. Replacement (Request A/S). 2. Replacement (Request A/S). 3. Replacement after checking.
	Motor is operating but lift is not moving up.	1. Check if the rotating direction of motor is correct. 2. Check if hydraulic lines is damaged.	1. Re-operate after changing the phase connection. 2. Refer to check points for hydraulic cylinder and unit.

Maintenance

Checklist and periodic maintenance

Inspection period	Points to be checked	Items to be checked	Inspection method	Action to be taken	Replacement period
1 week	Rubber Support for adjustment	Abrasion and deformation	Visual	Replacement	1 year
	Magnetic contactor	Damage of contact	Measurement	Replacement	2 year
3 months	Wire Rope	Abrasion, deformation and Breaking of wire	Visual	Replacement	2 year
	Post Guide	Abrasion	Visual	Replacement	4 year
	DU bush	Abrasion	Visual	Replacement	4 year
	Axle for wire pulley	Noise and abrasion	Visual	Replacement	5 year
	Wire pulley	Abrasion	Visual	Replacement	5 year
6 months	Electrical components	Damage of components	Measurement	Replacement	3 year
	Hydraulic Oil	Shortage of oil	Visual	Replacement	1 year
1 year	Piston Seal Kit	Oil leak or deformation	Visual	Replacement	3 year
	Load Seal Kit	Oil leak or deformation	Visual	Replacement	3 year